

★ ★ ★ ★ ★  
STARPATH®

# PRODUCT CATALOG 2014



Courses



Books



Software



Instruments



# CONTENTS



<b>COURSES/ACCESSORIES.....</b>	<b>3</b>
Celestial Navigation .....	4
Marine Weather .....	4
Inland & Coastal Navigation .....	5
Marine Radar .....	5
Assorted Accessories .....	8

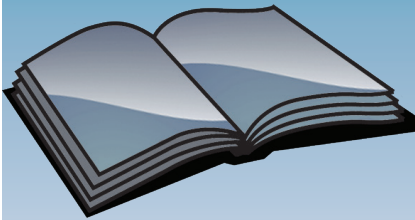

<b>BOOKS .....</b>	<b>9</b>
Celestial Navigation .....	10
Robert E. Peary at the North Pole.....	11
Secrets of the Viking Navigators .....	12
The Barometer Handbook.....	13
Portney's Ponderables .....	14
International Code of Signals .....	15
Modern Marine Weather, 2nd Ed. ....	16
Modern Marine Weather Workbook .....	17
Tidal Currents of Puget Sound .....	18
Long Term Almanac.....	19
Sailor's Logbook.....	19
Inland & Coastal Navigation, 2nd Ed. ....	20
Inland & Coastal Navigation Workbook.....	21
Navigation Workbook 1210 Tr.....	22
Annotated Navigation Rules.....	23
The Star Finder Book, 2nd Ed.....	24
The Stark Tables .....	25
Notfall Navigation .....	26
How to Use Plastic Sextants .....	27
The 1981 Nautical Almanac .....	28
Radar Workbook .....	29
Ocean Navigation Practice Voyage.....	30
Mariner's Pressure Atlas .....	31
Mariner's Guide to Worldwide Weather Maps.....	32
Lunar Almanac .....	32



<b>SOFTWARE .....</b>	<b>33</b>
Radar Trainer .....	34
Weather Trainer Live .....	36
Chart Trainer .....	38
Nav Rules Trainer .....	40
Bowditch Plus!.....	42
Engineer's Library .....	43
Engineering Examiner.....	44
Captain's Examiner .....	45
The Perpetual Almanac.....	46



<b>FISCHER COLLECTION .....</b>	<b>47</b>
---------------------------------	-----------

## CONTACT

Starpath Publications  
3050 NW 63rd Street  
Seattle, WA 98107

tel 206-783-1414  
toll free 800-955-8328  
fax 206-783-9209  
helpdesk@starpath.com

[www.starpath.com](http://www.starpath.com)

## INTERNATIONAL DISTRIBUTION

Starpath publications are printed simultaneously in the USA, United Kingdom, and Australia. Domestic shipping rates are available in those areas.

# ONLINE COURSES

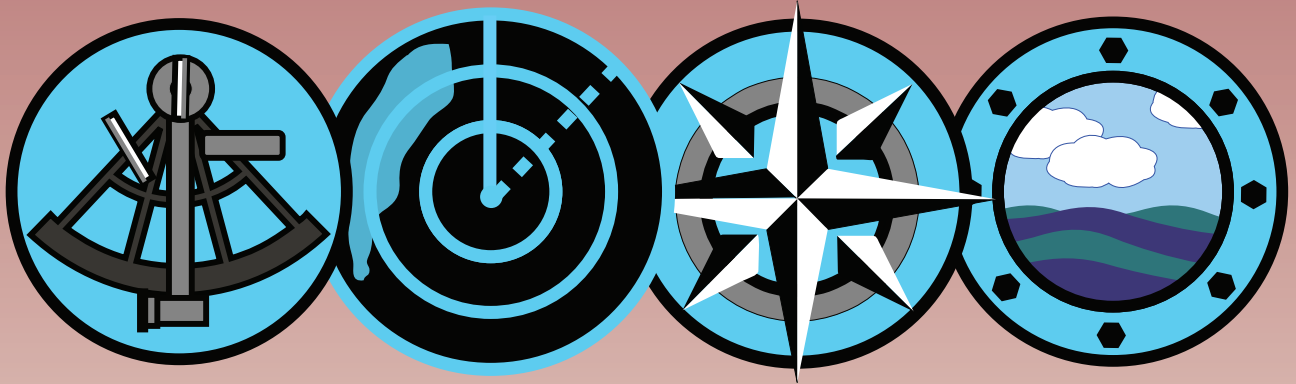

**Click any course to purchase and enroll online**



## Celestial Navigation

This course covers how to find position at sea from timed sextant sights of the sun, moon, stars, and planets plus other routine and special procedures of safe, efficient offshore navigation. No previous navigation experience is required — the only math involved is arithmetic (adding and subtracting angles and times). This is a practical, how-to-do-it course, which also includes clear explanations of how it works and how to do it well. Plus this course includes other crucial factors of ocean navigation besides just finding out where you are from the stars, such as logbook procedures, dead reckoning, error analysis, route planning, etc. At the end of this course, you will be ready for ocean navigation. Thousands of students have successfully learned celestial from these materials and gone on to cross oceans or circumnavigate the globe.

And you will not be left studying on your own. Registered for our course, you are just a keyboard click away from individual personal help whenever you need it.

All text materials are provided to complete the course. The only thing extra you might need are basic plotting tools (parallel rules, dividers and protractor). If you have no tools now, then our plotting tool kit will provide what you need... not just for the course, but for all of your future navigation underway as well.



## Marine Weather

This course covers all aspects of practical marine weather, starting from the very basics and ending with all you need to plan your voyages — or weekend outings — safely and efficiently taking into account the weather. This is intended to be a practical course that will indeed affect your decision making when planning and underway. We only cover those aspects of the “theory” that will help us with this goal.

This course uses live weather data accessed through custom Internet links to illustrate many of the topics it covers. We will also monitor a hypothetical coastal or ocean passage at the time of the course to see how the real world evolved and what decisions might be best at the time.

Includes the textbook Modern Marine Weather By David Burch and the Weather Trainer Live software program



## Inland & Coastal Navigation

Practical small-craft navigation (sail or power) starting from the basics and ending with all that is needed to navigate safely and efficiently on inland and coastal waters in all weather conditions. For beginners and more experienced mariners alike. All materials are provided except plotting tools.

No prerequisites are required, we start from the basics. Many thousands of students have successfully learned navigation from these materials and gone on to bare boat chartering or day sailing or world cruising in their own boats.

Includes a total paper course package, a complete electronic version of the entire course plus additional software resources, an electronic chart viewer and simulator as well as enrollment in the Starpath Online Coastal Navigation Course.

With this versatile package you can learn both traditional and electronic navigation at the same time — solve the practice problems in the traditional manner on a paper chart with standard plotting tools and also solve the problems electronically in an echart program using waypoints, bearing lines, and range rings.

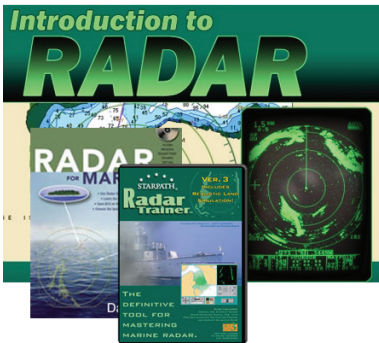

## Marine Radar

The course covers all aspects of practical radar usage that would be needed to get underway using your radar. It covers the topics of the text book Radar For Mariners and fills in the details on radar functions and operations while honing your skills with more emphasis on evaluating risk of collision and subsequent maneuvers that might be called for.

Includes the Textbook Radar For Mariners By David Burch and the Radar Trainer PC simulator program.



## Davis Mk 15 Sextant

This model has many features of traditional sextants including 7 large sunshades, telescope (3 x 27), and micrometer drum vernier scale that reads to 0.2'. The Mark 15 has a standard 7" (18 cm) frame radius graduated from 120° to -5° and comes with a traditional half-silvered mirror, as well as the sight tube shown in the picture — although there would rarely be need for that device; normally you would use the telescope (the tube looks good in the picture, however!).

It comes with very good instruction booklet. All replacement parts (even the screws!) are readily available. Well cared for, this instrument will last a life time, and you could indeed circumnavigate the globe with this device as your guide — and our booklet on how to use it.



## Astra III B Sextant

This instrument is made in China; it is the latest version of the popular Astra IIIb model. Upgrades included new box, improved lighting, and larger index mirror. The Astra sextant is the most popular sextant in the world at the moment, because of its low cost — the next step up in competing models is some \$1,000 or so. The Astra is dependable and more than accurate enough for the job. It is highly unlikely that any navigator regardless of experience could do more accurate navigation underway in a small vessel with any other sextant, even those costing \$2,000 or more.

This aluminum-alloy instrument at some 2.7 pounds is, in fact, easier to use than the traditional 4-pound brass models of the more expensive units. The Astra optics are excellent and the instrument has a good feel to it. Note that aluminum alloy sextants are not unique to this Chinese manufacturer, even the makers of the expensive brass versions offer aluminum alloy models, sometimes even more expensive than their brass models.



## Assorted Plotting Tools

The full collection of all tools needed for routine and special navigation plotting.

Pack includes:

15-inch parallel rulers

Weems plotter

Speed-bow dividers

15-inch ruler w/ protractor

5-inch square protractor





# BOOKS

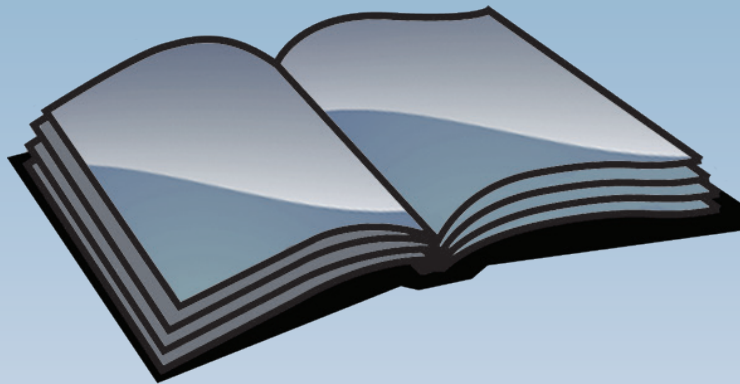

**Click any item to purchase online**

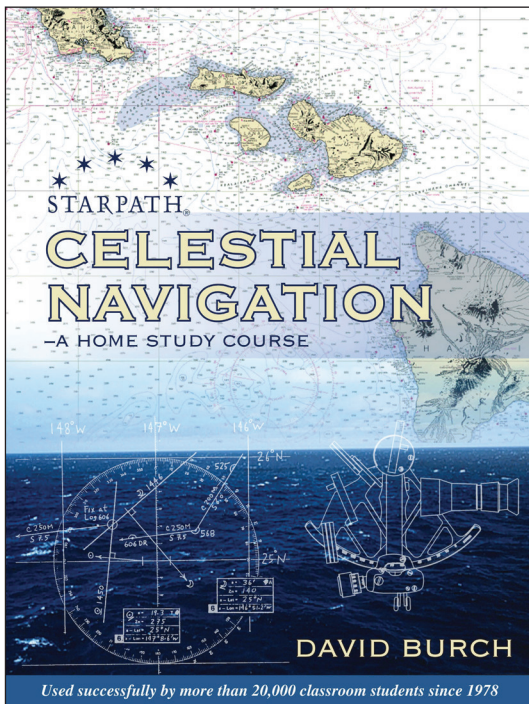

\$39.00, ISBN 978-0-914025-01-6  
247 pages, 8.25"x11"

"Thank you very much for your truly outstanding course in celestial navigation. The presentation was thoroughly professional in every way and, lots of fun." — Captain T K

"Thanks again for your terrific course. I enjoyed the course and even more, I was pleased with the real-world results at sea." — Dr. L K

"I highly recommend your course to anybody that wants to learn and use celestial navigation." — J S G, 1600 ton Master (Oceans)

**David Burch** is a recipient of the Institute of Navigation's Superior Achievement Award for outstanding performance as a practicing navigator. He has logged more than 70,000 miles at sea including twelve transoceanic yacht races, with several first place victories and a passage record that lasted 16 years. On the academic side, he is a former Fulbright Scholar with a PhD in Physics. In 2011 he was awarded Fellow Grade in both the US Institute of Navigation in Washington DC, and the Royal Institute of Navigation in London

## Celestial Navigation

### A Home Study Course

by David Burch

This book, an entire home study course within itself, covers how to find position at sea from timed sextant sights of the sun, moon, stars, and planets plus other routine and special procedures of safe, efficient offshore navigation. No previous navigation experience is required—the only math involved is arithmetic (adding and subtracting angles and times). This is a practical course, which includes clear explanations of how it works and how to do it well. Plus this course includes other crucial factors of ocean navigation besides just finding out where you are from the stars, such as logbook procedures, dead reckoning, error analysis, route planning, etc. At the end of this course, you will be ready for ocean navigation. Thousands of mariners have successfully learned celestial from these materials and gone on to cross oceans and circumnavigate the globe.

The course is designed around a unique work form that makes all sextant sights essentially the same. The form and procedures have been developed and tested with the help of tens of thousands of students over the past 25 years.

You will soon be doing the sextant-sight reductions of the sun, moon, stars, and planets, with little more than a glance at the work form. It reminds you what to do at each step, and then carries you on to the next.

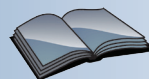

# Robert E. Peary at the North Pole

## *A Report to the National Geographic Society*

by Adm. Thomas D. Davies

Commander Robert E. Peary and his long time assistant Matthew Henson, along with four young Inuit men, Ootah, Egingwah, Seegloo, and Oogueah had reached the North Pole by dog sled on April 6, 1909. Logistical support was coordinated by Capt. Bob Bartlett, skipper of Peary's ship, the *Roosevelt*, along with a select crew of scientists and explorers, a large contingent of Inuit men and women, and 133 sled dogs.

From the very beginning there have been skeptics of this achievement and numerous assaults on Peary's integrity. The challenge was initially fueled by a completely forged claim of an earlier discovery by Dr. Frederick Cook, a former surgeon on one of Peary's expeditions, who had deceived much of the public and several influential persons into believing he had been to the Pole earlier than Peary.

Even after it was unambiguously established that Cook's claim was fraudulent, damage to Peary's cause had been done. Politics and personalities of the central figures overshadowed clear reasoning in much of the debate. As the renown Arctic explorer Dr. Vilhjalmur Stefansson put it at the time "Cook was a liar and a gentleman; Peary was neither."

There followed a relentless string of accusations against Peary, each based on a lack of knowledge of the expedition and of the navigation techniques involved. Even today, it remains easier to find in print and online more doubts about Peary's accomplishment than informed analysis and praise for it.

The persistence of this misinformation is in large part because this book has not been more readily available. This research by professional navigators and scientists laid to rest the question, once and for all, that Peary did indeed reach the Pole as he claimed. Each aspect of the navigation and travel are analyzed, and the details are presented here. As shown in a new Supplement, even subsequent challenges to this report itself have been readily dispelled.

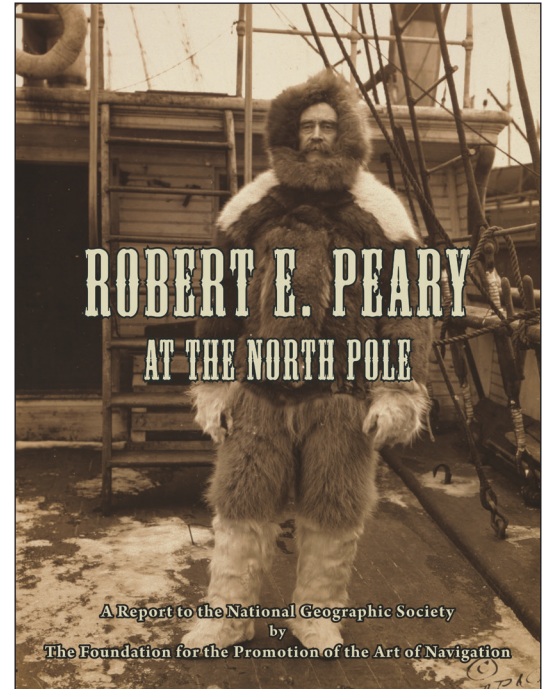

\$39.00, ISBN 978-0-914025-20-7  
305 pages, Vintage Photographs, 8.25"x11"

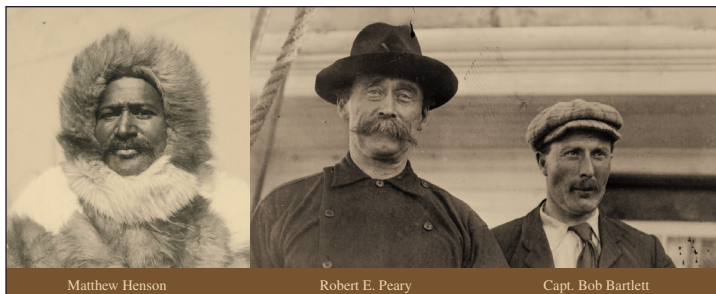

"I consider this the end of a historic controversy and the confirmation of due justice to a great explorer."

— Gilbert M. Grosvenor, President National Geographic Society



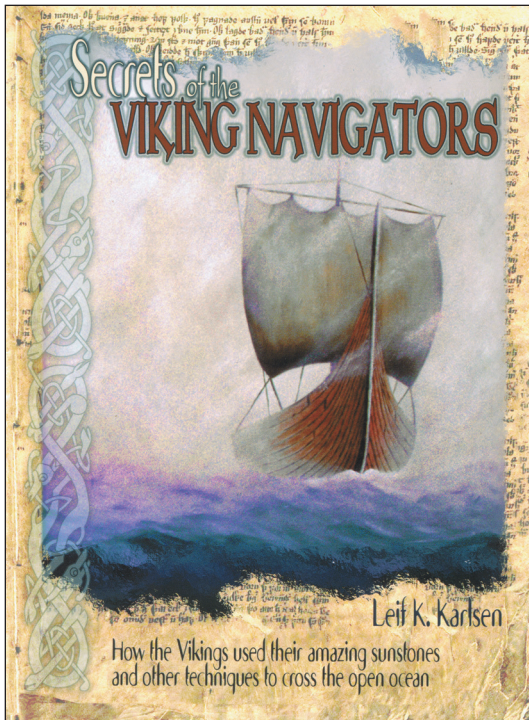

\$19.95, ISBN 0-9721515-0-8  
222 pages, Color photos, 7"x10"

## Secrets of the Viking Navigators

### *How the Vikings used their Amazing Sunstones and other Techniques to Cross the Open Ocean*

by Leif K. Karlsen

Most navigators have heard of Viking sunstones, but few realize they are more than legend. Leif Karlsen has brought them to life. He shows us how they work—now, and a thousand years ago—and what it was that led the Viking navigators to develop this unique tool for finding the direction to the sun, even when the sun is obscured by clouds or fog.

“Using clues he gleaned from the Icelandic Sagas, his experience as a professional navigator, and from his voyages on “Borgunknarren”—a 60’ Viking ship replica—Leif K. Karlsen reveals the secrets of Viking navigation. Karlsen has done extensive research on the Viking “sunstone” and “horizon board” and explains how they work. This is an interesting, valuable, and educational contribution to the understanding of the Vikings’ success as navigators and seamen.” — Dr. Alf Lunder Knudsen, Editor Emeritus Western Viking The Norwegian Voice of America -Since 1889

“If ‘cutting edge’ can be used in relation to Viking navigation, this information is definitely it. Leif Karlsen is the world’s foremost scholar on the Viking sunstone. His well-researched and intelligent work on Viking navigation examines the sagas and combines that information with the experiential and practical research of just trying it out. It’s a comprehensive and accessible study that’s also a compelling analysis of the secrets of Viking navigators, and their unparalleled success as sea-born explorers.” — Kristine Leander, Ph.D., Director, Leif Erikson International Foundation



**Leif K. Karlsen** had 45 years of experience at sea in the North Atlantic where he served as a professional navigator and radio electronics officer with the U.S. Merchant Marine. He died in 2009 and is much missed by all who knew him.



# The Barometer Handbook

## *A Modern look at Barometers and Applications of Barometric Pressure*

by David Burch

The barometer remains the most important tool for evaluating and predicting the weather. This book explains why knowing accurate values of the atmospheric pressure can improve this process and benefit all applications. Ways to evaluate and calibrate aneroid and electronic barometers using readily available data by Internet or telephone are clearly described. Tactical applications to marine navigation are covered. The book also includes worldwide average monthly pressures and their standard deviations

"...takes the reader on an entertaining and informative trip through the history and use of this critical tool and provides a look at how barometric pressure effects climate and our weather." — Peter Isler, two-time America's Cup winning navigator.

"...offers practical advice for choosing the right barometer for the job and discusses the advantages and disadvantages of each in great detail. ...excellent bibliography. ...an easy read, filled with practical applications for an instrument that is commonly found aboard, but rarely used to its full potential. It belongs in any shipboard library. A must have companion for Burch's *Modern Marine Weather*. — Ocean Navigator Magazine, Nov/Dec, 2009

"...the only comprehensive book on barometers that a mariner can refer to that will ensure how important it is to not only have a barometer when coastal or blue water cruising. ....alongside his *Modern Marine Weather* these books should serve as bookends for Bowditch. — Lee Chesneau, senior marine forecaster, Ocean Prediction Center, NWS, popular lecturer and teacher, and co-author of *Heavy Weather Avoidance—Concepts and Applications of 500-mb charts*.

"Having read a number of books on barometry over the years, I have to admit that this book has to be the most useful particularly from a weather practitioner's perspective. In fact there is a bit for everyone who has an interest in atmospheric pressure and weather in general." — Kenn Batt, Manager, Canberra Meteorological Office, Bureau of Meteorology, Canberra ACT Australia

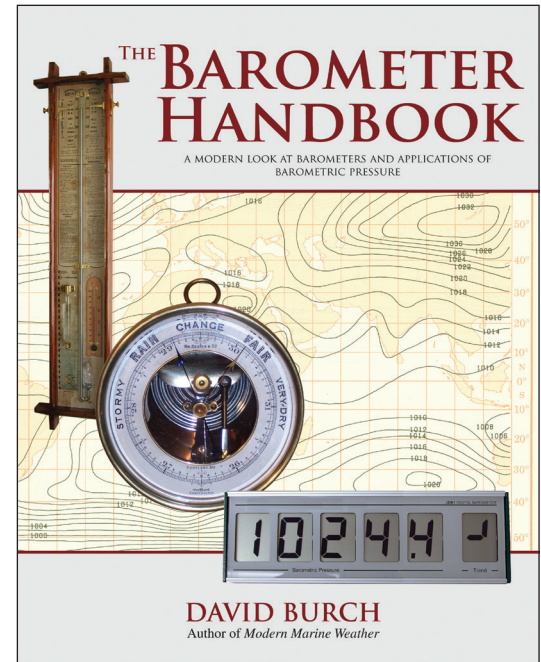

\$29.95, ISBN 978-0-914025-12-2  
239 pages, 7.5"x9.25"

"This is great stuff. It's the kind of book I wish I had when I started my career."

— Christopher Hampel, Calibration Scientist,  
Barometry, Environment Canada



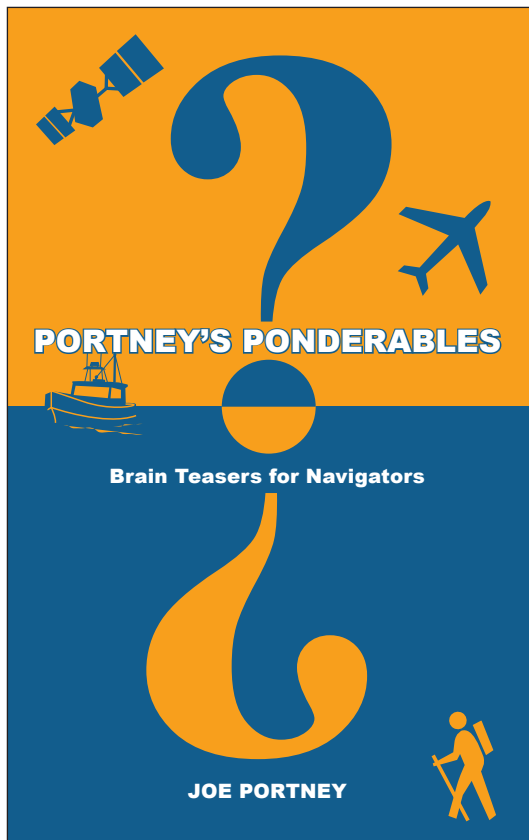

\$9.95, ISBN 978-0-914025-19-1  
157 pages, 5"x8"

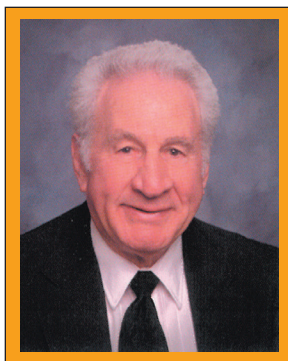

**Joe Portney** is a US Naval Academy graduate and Air Force navigator who has participated in three historic flights over the North Pole. He is a past President of the Institute of Navigation and recipient of the Weems Award for continuing contributions to the art and science of navigation.

## Portney's Ponderables

### *Brain Teasers for Navigators*

by Joe Portney

*Navigation puzzles, controversies, historical problems, and other ponderables demystified by an expert navigator and writer.*

Joe Portney has produced a wonderful little book here, chock filled with interesting tidbits, each of which can be read in a few minutes but will stimulate your thought for many days to come. Some are very basic, others more involved, but he provides a clear explanation of each. Some refer to math computations that we might not all be familiar with, but this is not a distraction from the main points being made even in these few cases.

A great gift for your favorite navigator, including yourself!

#### NAVIGATION FIRSTS

Columbus Found Longitude?  
Which Way Did They Go?  
Peary and Henson at the Pole  
The Polar Flap  
Lucky Lindy  
Graf Zeppelin Around-the-World Flight

#### LOST AND FOUND

Lost and Found at Sea or Ground  
Demise of the Errant Balloon  
Lady Be Good  
Mayday in December

#### THE COSMOS

How High the Mountain  
Voyage to Arcturus  
Jack and the Ropestalk  
Transpo 2K+

#### EXPERIMENTS

Moline Missile Proving Grounds  
Navigating the Bermuda Triangle  
Watch What You Say  
3D With Hall a Pair  
The Long and the Short of Flights  
Captain Omen's Voyage under the  
Polar Seas

Noah Kalendar  
Joggers Dilemma  
Age of Maturity

#### APPENDIX

1 - How High the Mountain  
2 - Buffon's needle

#### BIBLIOGRAPHY

#### GLOSSARY

#### ANSWERS

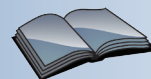



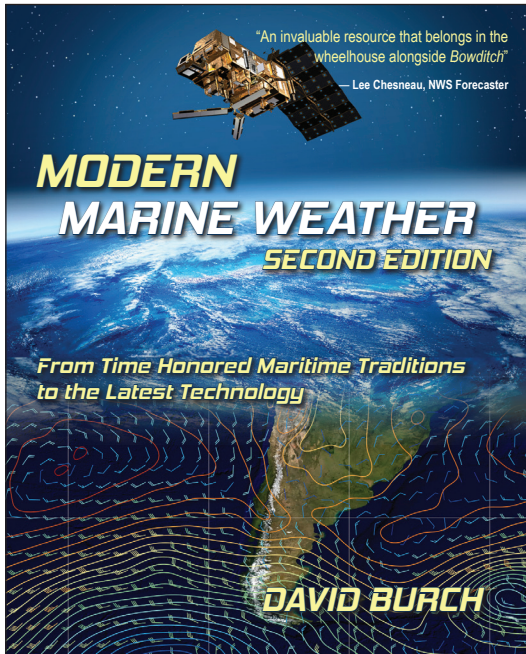

\$39.00, ISBN 978-0-914025-33-7  
326 pages, 7.5"x9.25"

## Modern Marine Weather, 2nd Ed. *From Time honored Maritime Traditions to the Latest Technology*

by David Burch

A new, comprehensive text on how to take weather into account for the planning and navigation of voyages, local or global, using the latest technologies as well as the time-honored skills of maritime tradition, so that your time on the water remains as safe and efficient as possible.

"No subject is more important to every sailor than the wind and its direction. Modern Marine Weather is first class reference book on the subject of marine weather and the information it contains will help every sailor, every day!

— Peter Isler, two-time America's Cup winning navigator.

"*Modern Marine Weather* is an instant classic. If you own one book about weather this is it. If you are navigating across the Pacific, the Atlantic or the Equator you'll make better decisions and truly understand the machinery behind the wind, waves, and currents after studying this book. If you are preparing for an Olympic regatta in Melbourne, Weymouth or San Francisco and want to make your own intelligent forecast and pick-up local knowledge like a local, you will find all the information in this most excellent book. Serious about weather and navigation: Get *Modern Marine Weather* by David Burch."

—Philippe Kahn, CEO of FullPower Technologies, and Doublehanded Trans-pacific elapsed time record holder, and other worldclass achievements of his Pegasus Racing Team.

"In fifteen years as a Navy officer, Annapolis grad, surface navigator, and oceanographer this is by far the best practical sailing weather book written."

— LCDR Brady Brown, U.S. Naval Observatory

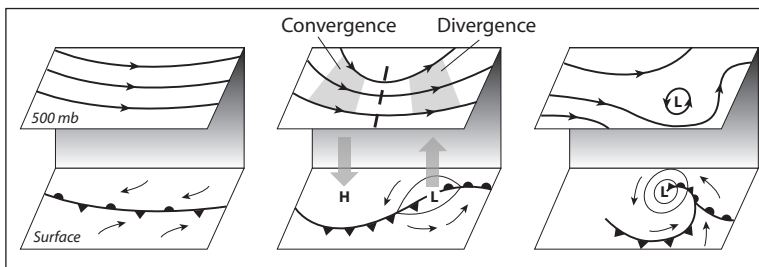

**Figure 4.3-8** from *Modern Marine Weather* Lows often form under the divergence zone just down stream of a trough aloft in the 500 mb winds. Compare 500-mb maps with the corresponding surface analysis maps to see the effect. The important concept of divergence is illustrated in Figure 4.3-12.

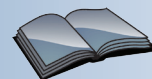



# Modern Marine Weather Workbook

## Questions, Answers and Resources on Marine Weather

by David Burch

This workbook is intended to supplement the text *Modern Marine Weather* with practice questions and convenient resources. All answers are provided. The Lesson structure here matches the chapter structure in the textbook. There are multiple choice questions and “points to ponder” questions for each of the ten chapters.

### More praise for Modern Marine Weather...

“*Modern Marine Weather* is an essential reference for the coastal and offshore sailor. It goes far beyond the traditional “marine weather” books. There may be new tools available for weather forecasting, but weather itself has been around a very long time and David does an excellent job of laying proper foundations for understanding marine weather, and bringing clarity to a complex topic.” —Jim Corenman, racing and cruising sailor, and developer of the Saildocs and SailMail programs for weather and communications used by thousands of mariners, worldwide.

“This is the definitive text for those wanting to learn more about marine meteorology. It’s a shame that this book wasn’t around when I was studying marine meteorology. It would have made the job a lot easier. David Burch should be applauded for this beautiful piece of work.” —Kenn Batt, Manager, Canberra Meteorological Office, Australian Bureau of Meteorology, weather briefer for participants in the Sydney to Hobart Yacht Race, and active racing sailor.

The 21st Century is bringing us a rapid evolution in weather information available to the common sailor. *Modern Marine Weather* points out where to find the best stuff quickly. The book also gives a thorough review of how to read weather maps and digest storms warnings, as well as tips on how to read clouds and use the wind to win coastal yacht races, or how to interpret GRIB data and Scatterometer pilot charts on Google Earth to sail comfortably across an ocean. —Bob McDavitt, MetService (NZ) Weather Ambassador and forecaster for EarthRace, the holder of the fastest ever circumnavigation by a powerboat.

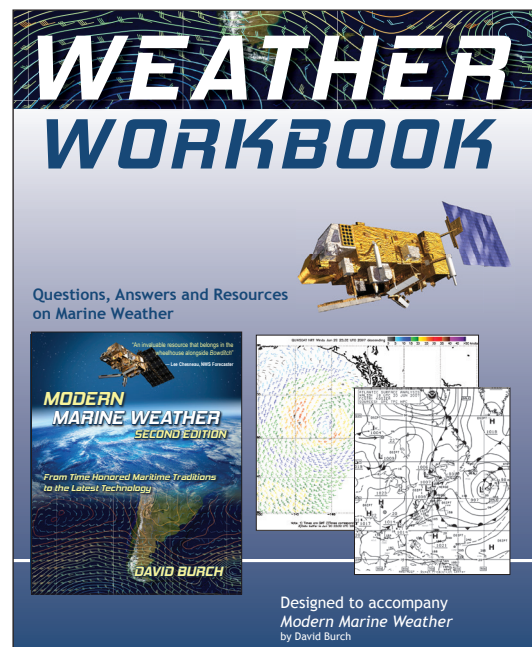

\$19.95, ISBN 978-0-914025-09-2  
68 pages, 8.25"x11"



Graphic current charts and flow patterns

# TIDAL CURRENTS of PUGET SOUND



\$19.95, ISBN 978-0-914025-16-0  
88 pages, 8.25"x11"

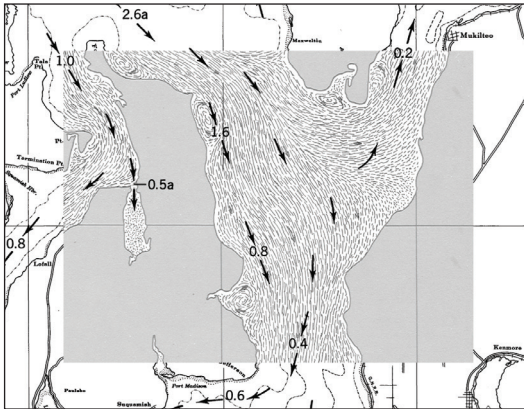

## Tidal Currents of Puget Sound Graphic Current Charts and Flow Patterns

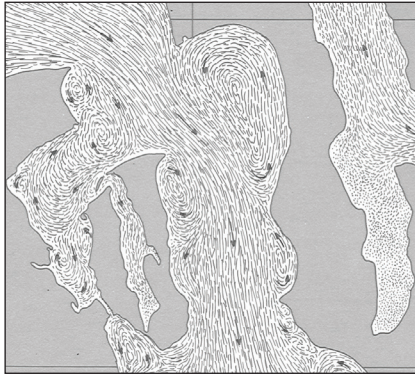

*Tide Prints* show the flow patterns and how they evolve throughout the current cycle. There is one print for every 3 hours throughout the cycle. They are indexed to the tide height in Seattle.

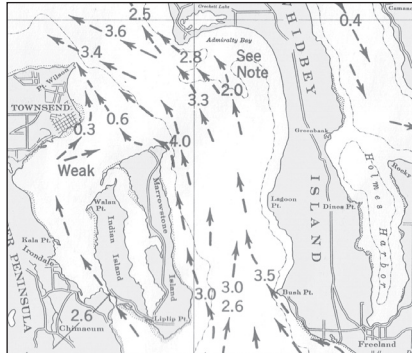

*Current Charts* show the values of the currents at each reference station. There is one chart for every hour throughout the cycle. They are indexed to the tidal current at Admiralty Inlet.

Comparing *Tide Prints* and *Current Charts* shows the locations of eddies and bands of current, and how these bands and eddies move and interact as the current cycle evolves.

- These are both perpetual publications, good for any year.
- Tide data at Seattle and current data at Admiralty Inlet (off Bush Pt) and at Tacoma Narrows (north end), are needed to assign specific times to each page of these charts and prints.



# Long Term Almanac

*For the Sun and Selected Stars With Concise Sight*

*Reduction Tables*

by Geoffrey Kolbe

***The ideal one-book back-up to GPS.***

Nautical almanac data for the sun and selected stars valid until 2050, plus easy to use, concise sight reduction and altitude correction tables. Plus work forms to make the process even easier. A concise one-book solution for celestial navigation. It takes a few extra steps to get GHA and dec with the *Long Term Almanac*, since it does it without the usual 10 pounds of reference books, but with practice it takes just a few minutes longer than normal almanac look up.

All the information you need for

- Finding your position from timed sextant sights
- Checking your compass by celestial bearings
- Computing great circle routes to your destination

# Sailor's Logbook

by David Burch

The simple layout of these record sheets has been tested over thousands of miles of offshore and coastal sailing. Use the hourly numbered entries for racing, or enter as needed for cruising.

The ship's logbook has been a maritime tradition since ancient times. It is the place to document the voyages and movement of the vessel and events that take place on board related to safe navigation and the well being of the crew and cargo. Required log entries (not related to navigation) are specified for some vessels in 46 USC 11301. This logbook is intended as a navigation log, with spare pages in the back for other entries.

***Designed for sailors by sailors.***

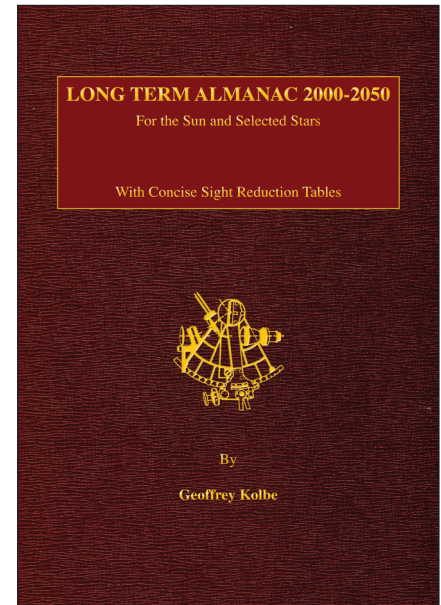

\$29.95, ISBN 978-0-914025-10-8  
111 pages, 7"x10"

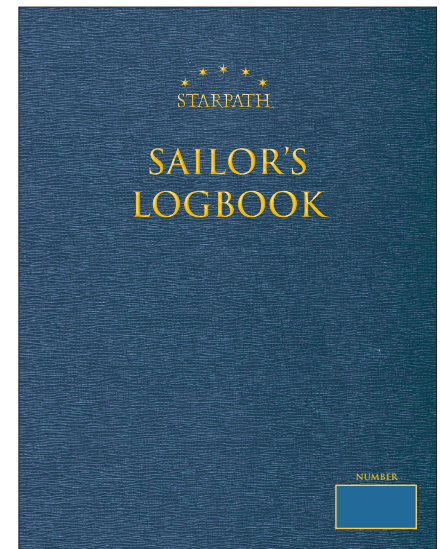

\$19.95, ISBN 978-0-914025-28-3  
90 pages, 8.5"x11"



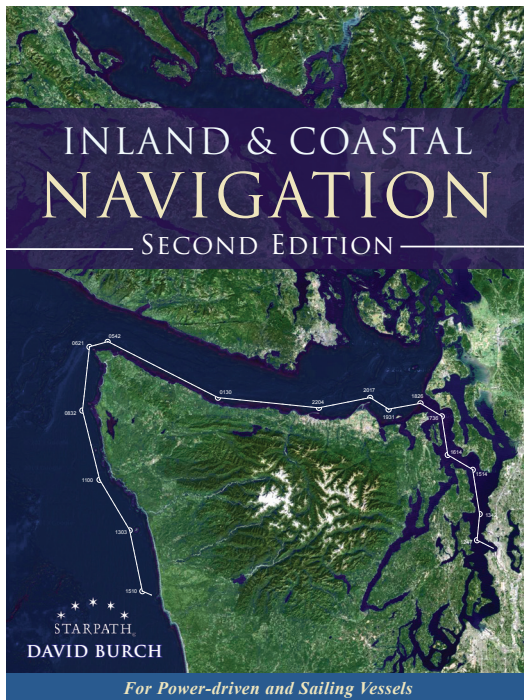

\$39.00, ISBN 978-0-914025-40-5  
201 pages, 8.25"x11"

## Inland & Coastal Navigation, 2nd Ed.

by David Burch

This book is an updated edition of a text that has been used in navigation courses for 30 years. It covers practical small-craft navigation (sail or power), starting from the basics and ending with all that is needed to navigate safely and efficiently on inland and coastal waters in all weather conditions. It is for beginners, starting from scratch, or for more seasoned mariners who wish to expand their skills.

*Topics include:*

- Charts, Chart Reading, and Chart Plotting
- Instruments and Logbook Procedures
- Compass Use
- Piloting and Dead Reckoning
- Lights and Buoyage
- Tides and Currents
- Rules of the Road
- GPS and other Electronic Aids

The GPS tells us where we are and how fast we are moving in what direction, but it can never tell us the safest, fastest route to our destination. That fundamental task requires the basic navigation skills taught in this book.

And the first thing we learn is not to rely on any single source, not even the GPS itself. The skills taught in this book are what we need to check the GPS underway, and to be prepared to navigate without the GPS if it should fail.

We have gotten great results using your Coastal Nav course as a refresher for both my junior quartermasters, and junior deck officers. Two Petty Officers who were advanced on the most recent promotion exam largely credit this course for pushing them over the edge into the next rank.

—CDR Tate Westbrook, USN  
Commanding Officer  
US NAVY DESTROYER SPRUANCE (DDG 111)



# Inland & Coastal Navigation Workbook

*For Use with Paper and Electronic Charts*

by David Burch

This book provides over 100 exercises with answers covering all aspects of small-craft navigation. These are practical problems that all navigators should know how to solve. The level of the exercises is about that used in the USCG 100-Ton masters exam, which in turn is about the same used in the navigation certification programs of US Sailing, ASA, CYA and RYA. These practice problems are, however, designed to be practical and instructive, not just training exercises for certification exams. This Workbook is used by several navigation schools around the country.

Selections are provided from each of these special publications along with exercises to insure their full use is mastered:

Tide Tables • Current Tables • US Coast Pilot • USCG Light List • USCG Notices to Mariners • NOAA Chart Catalog

The exercises that require a chart use nautical training chart No. 18465tr, available at reduced price from NOAA chart dealers, or by telephone from NOAA at (800) 638-8972, or by online order at [www.nauticalcharts.noaa.gov](http://www.nauticalcharts.noaa.gov) or [www.starpath.com/18465](http://www.starpath.com/18465).

You can also work the chart problems with an electronic chart (Raster Navigation Chart, RNC) number 18465, available at no charge as a download from [www.starpath.com/18465](http://www.starpath.com/18465). The echart can be viewed by any of several free echart viewer programs listed in this book. You can also use any full echart navigation program of your choice. We encourage navigators to solve the chart problems with both traditional paper plotting as well as electronically, using electronic bearing lines and range rings.

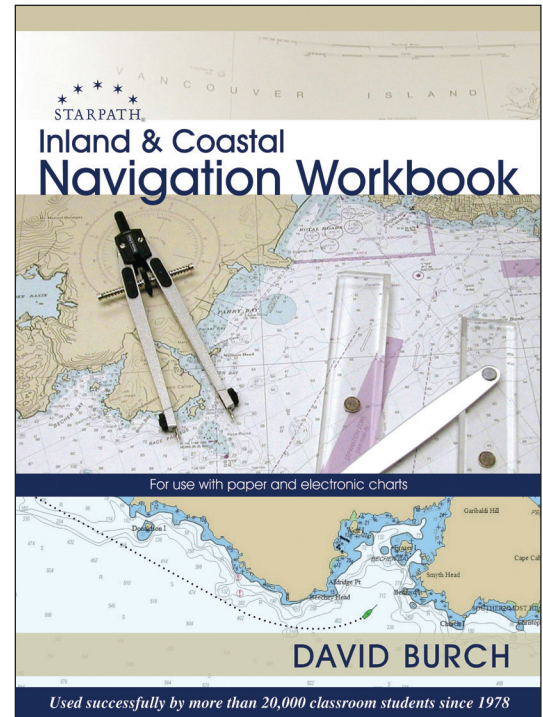

\$19.95, ISBN 978-0-914025-13-9  
103 pages, 8.25"x11"



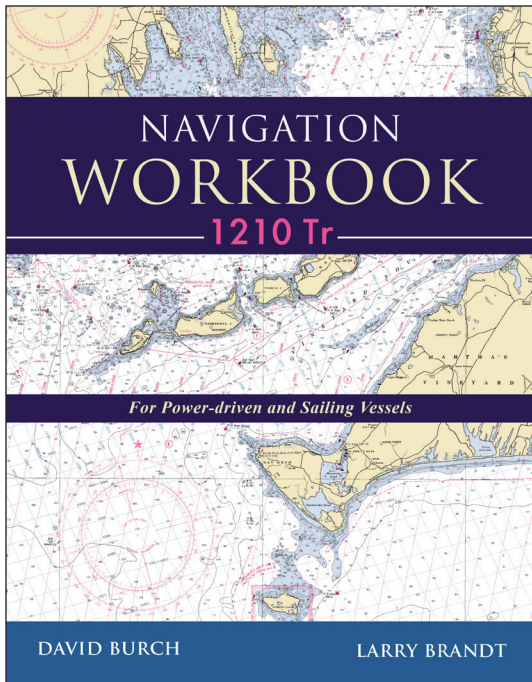

\$19.95, ISBN 978-0-914025-44-3  
120 pages, 8.25"x11"

## **Navigation Workbook 1210 Tr** ***For Power-driven and Sailing Vessels*** by David Burch and Larry Brandt

This book provides over 100 exercises with answers covering all aspects of small-craft navigation. These are practical problems that all navigators should know how to solve. The level of the exercises is about that used in the USCG 100-Ton masters exam, which in turn is about the same used in the navigation certification programs of US Sailing, ASA, CYA and RYA. These practice problems are, however, designed to be practical and instructive, not just training exercises for certification exams. This Workbook is used by several navigation schools around the country.

Selections are provided from each of these special publications along with exercises to insure their full use is mastered:

Tide Tables • Current Tables • US Coast Pilot • USCG Light List • USCG Notices to Mariners • NOAA Chart Catalog

The exercises that require a chart use nautical training chart No. 1210 Tr, available at reduced price from NOAA chart dealers, or by telephone from NOAA at (800) 638-8972, or by online order at [www.nauticalcharts.noaa.gov](http://www.nauticalcharts.noaa.gov) or [www.starpath.com/navbook](http://www.starpath.com/navbook).

You can also work the chart problems with an electronic chart (Raster Navigation Chart, RNC) number 1210 Tr, available at no charge as a download from [www.starpath.com/navbook](http://www.starpath.com/navbook). The echart can be viewed by any of several free echart viewer programs listed in this book. You can also use any full echart navigation program of your choice. We encourage navigators to solve the chart problems with both traditional paper plotting as well as electronically, using electronic bearing lines and range rings.

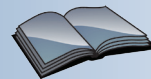

# Annotated Navigation Rules

This is a new print edition of a book we had offered previously only in e-book format. It is the full Navigation Rules book, just as would be purchased without annotations, but this one has been carefully annotated to mark all differences between the US Inland Rules and the International Rules (Colregs). The differences are prominently color coded, as shown below.

This new edition also has Annexes and Supplements highlighted where applicable. It is up to date with all recent changes from the USCG including changes in the Demarcation Lines that separate these two waters.

Ideal resource if you sail both Inland and Coastal waters and for USCG license exam preparation.

**Yellow** means this Rule on the same subject is different in US Inland vs. International waters.

**Orange** means the Rule is unique to Inland Rules

**Blue** means the Rule unique to International Rules

**Green** means different wording, but no practical difference



\$29.00, ISBN 978-0-914025-43-6  
216 pages, 7"x10"

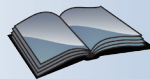

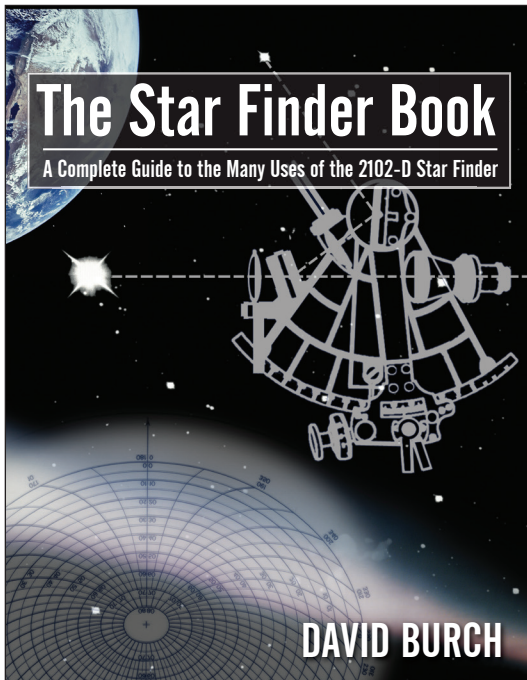

\$19.95, ISBN 978-0-914025-00-9  
62 pages, 7.5"x9.25"

## The Star Finder Book, 2nd Ed. *A Complete Guide to the Many Uses of the 2102-D Star Finder*

by David Burch

Some things change, some things stay the same. After more than 25 years in print, we find that the virtues and values of this book and the Star Finder it discusses have not changed. For navigators who might rely on celestial navigation, or for anyone who cares to learn more about star and planet ID and how these bodies move across the sky, this book remains a wonderful resource. The new redesigned format of the book makes it much easier to read than the earlier editions. It has also been enhanced with numerous diagrams on finding directions from the stars.

This book turns the 2102-D Star Finder into a hand-held planetarium, which will become your most important tool for star ID and for planning star and planet sights. It also includes many unique practical tables not found elsewhere, such as how to tell the best use of the moon from its age, how to compare brightness of stars and planets in an easy way, which stars are reddish, and more.

Includes a general discussion of choosing and optimizing star-planet sights and how to optimize sun-moon fixes during the day, along with general tips on practical celestial navigation. Plus how to use the Star Finder as a solar compass if your magnetic compass should fail.

Extensive realistic examples worked out in full numerical detail.

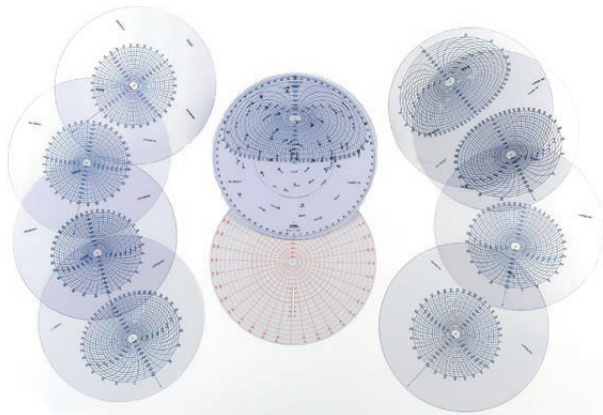

***The 2102-D Star Finder;  
A unique computer.***

***It works when it's wet, and it  
works if you drop it.***

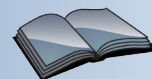



# The Stark Tables for Clearing the Lunar Distance

by Bruce Stark

Celestial navigation is a way to find your latitude and longitude on earth using a sextant to measure the angular heights of celestial bodies above the horizon. It has been used by mariners at sea and explorers on land for three hundred years, and it is still used today as a dependable backup to modern electronic navigation.

Routine celestial navigation relies upon accurate time (Universal Time) to find the longitude of a position (latitude does not require time). Advanced celestial navigators can find longitude without knowing the time using a technique called Lunar Distance. In this technique, the sextant is used to measure the angular (diagonal) distance between the moon and another celestial body. Since this distance slowly changes as the moon moves eastward though the stars, it can be used to find the time of day that is needed to complete the longitude determination.

The process of finding longitude from lunar distance, however, requires special tables that have not been published in the Nautical Almanac or other sources since the early 1900s.

Although software solutions have been available, most advanced celestial navigators are very grateful to navigation historian Bruce Stark for creating these printed tables dedicated to this task. They have been used and tested by mariners for more than 15 years and are praised by experts for their ingenuity and ease of use in solving this complex navigation exercise—which all agree is the hallmark of an expert celestial navigator.

With The Stark Tables in your nav station, you no longer have to fear losing power to your electronic navigation aids, nor are you dependent on accurate time from any official broadcast.

Besides their practical use in back up navigation, historians have used these tables for years to interpret the logbooks of Lewis and Clark, David Thompson, James Cook, Matthew Flinders, George Vancouver, Nathaniel Bowditch, and other notable explorers and sea captains.

“Bruce Stark has rendered a great service to the celestial navigation community.” — Navigation Foundation Newsletter

## STARK TABLES

FOR  
CLEARING THE LUNAR DISTANCE

AND  
FINDING UNIVERSAL TIME BY SEXTANT OBSERVATION



INCLUDING  
A CONVENIENT WAY TO SHARPEN  
CELESTIAL NAVIGATION SKILLS WHILE ON LAND

BRUCE STARK

\$39.00, ISBN 978-0-914025-21-4  
250 pages, 8.25"x11"



BOOKS



25

Orientierungsmethoden für den wissbegierigen und verantwortungsbewussten Seefahrer

# NOTFALL NAVIGATION

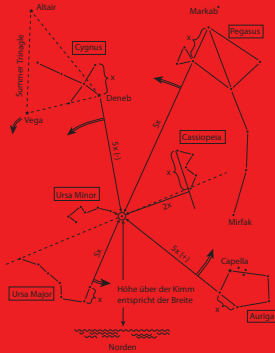

DAVID BURCH

übersetzt von PEER REEH & HEINZ RESSL

## Notfall Navigation

*Orientierungsmethoden für den wissbegierigen und verantwortungsbewussten Seefahrer*

von David Burch

übersetzt von Peer Reeh & Heinz Ressel

Das lange vergriffene Kultbuch von David Burch, einem der weltbesten Navigatoren und Gründer der Starpath School of Navigation, nun auf Deutsch neu erschienen. Kein Survival-Handbuch, sondern ein umfassendes Werk über die eigentlichen Grundlagen der Orientierung auf See, von den polynesischen Sternpfaden bis zum Steuern nach dem Wind und nach Wellenbildern. Wenn die Technik teilweise oder zur Gänze versagt sollte der verantwortungsbewusste Skipper oder Navigator zumindest einige der hier aufgearbeiteten Grundlagen um Kopf haben. Ein leicht verständliches Standardwerk für alle, die sich mit dem Hochsee-Segeln befassen.

\$39.00, ISBN 978-0-914025-17-7  
276 pages, 7"x10"

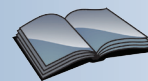
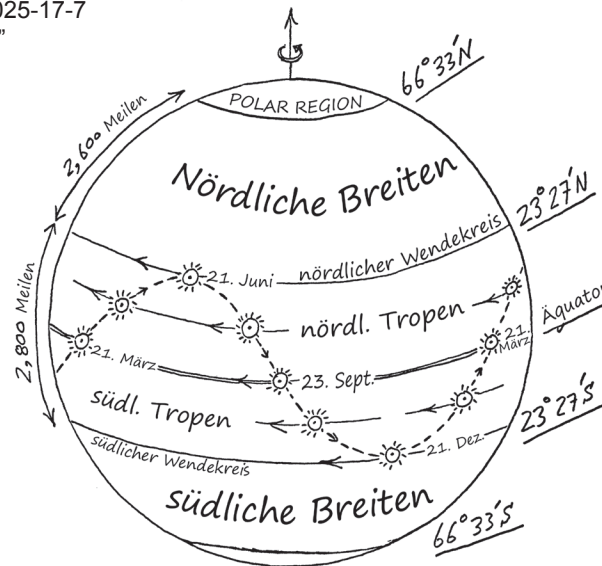

# How to Use Plastic Sextants

## *With Applications to Metal Sextants and a Review of Piloting*

by David Burch

Plastic sextants are often disparaged for lack of inherent accuracy and vulnerability to the effects of the sun, but these criticisms are typically overstated. While it is true they are not as accurate as metal sextants and they are indeed more sensitive to the sun than metal sextants are, plastic sextants can with special care still be used quite successfully for practical navigation at sea, and they provide a less-expensive alternative to metal sextants, for both new navigators or seasoned mariners looking for a back up to GPS. Plastic sextants are even preferable over metal ones for most sextant-piloting applications.

This book explains how to get the best results from these instruments, including step by step instructions for the sight taking, as well as numerical comparisons with metal sextants.

The focus of the book is on plastic sextants, because they present the biggest challenges, but if you master the use of them, you will be even much better with a metal sextant in your hand. In short, the sight taking and analysis procedures covered are the best way to do all sights, regardless of sextant style, it is just more crucial that we follow these procedures when using plastic sextants.

This new edition now includes a detailed discussion of sextant piloting on inland and coastal waters, which is not covered in many texts these days. With an inexpensive plastic sextant you can pinpoint your position on a map or chart more accurately than you can with GPS—not to mention it is more reliable as well... (oops. We mentioned it!).

***Will also improve your sights and skills with metal sextants***

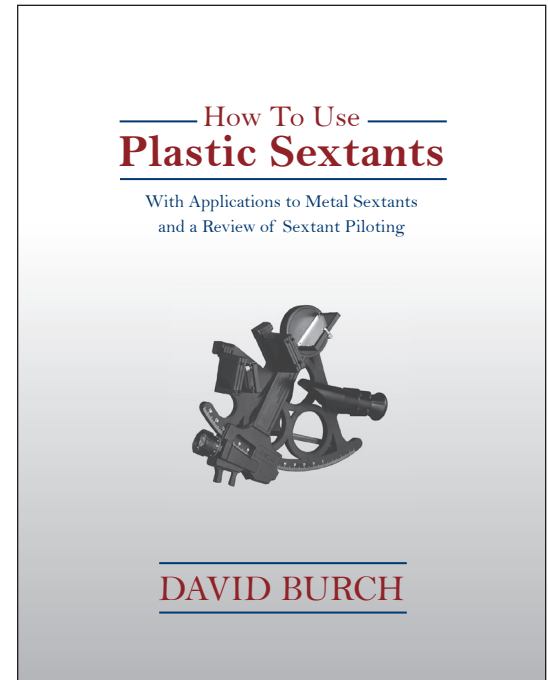

\$19.95, ISBN 978-0-914025-24-5  
98 pages, 7.5"x9.25"

“...a unique book with lots of very useful information and instructions about using a sextant, much of which translates very well to the understanding and use of metal sextants also. ...highly recommend it. It has excellent information on the how and why of index correction, as well as a terrific review on Sextant piloting.” — Scott, NavList

“...a very fine book with lots of information that’s valuable to both beginning and experienced navigators and navigation enthusiasts. BUY IT. Practically anything you can do with a sextant (apart from opening bottles of beer...) is covered in this book. It’s really good. The section on sextant piloting is more detailed than any other treatment that I have seen.” — FER, NavList



THE  
NAUTICAL ALMANAC

FOR THE YEAR

1981

FOR TRAINING PURPOSES ONLY

\$39.00, ISBN 978-0-914025-26-9  
314 pages, 7"x10"

# The 1981 Nautical Almanac

## For Training Purposes Only

by The Nautical Almanac Offices

Data in this book are no longer valid for navigation. It is preserved in print because many training programs (including USCG and US Navy ) use examples from 1981 to teach celestial navigation. USCG license exams require data from this almanac. These exams also require Sight Reduction Tables, Pub 229, Vol. 2 and a 2102-D Star Finder.

22 1981 JANUARY 19, 20, 21 (MON., TUES., WED.)											
G.M.T.	ARIES		VENUS -3.3		MARS +1.4		JUPITER -1.7		SATURN +0.9		Nor
	G.H.A.	Dec.	G.H.A.	Dec.	G.H.A.	Dec.	G.H.A.	Dec.	G.H.A.	Dec.	
19 00	118 17.9	197 48.1 S23 00.0	160 29.0 S17 23.3	288 15.3 S 2 49.0	288 21.0 S 1 37.9	Acerra					
01	133 20.4	212 47.2 22 59.8	175 29.5 22.7	303 17.7 49.0	303 23.5 1 37.9	Acherr					
02	148 22.9	227 46.2 59.7	190 30.0 22.1	318 20.1 49.0	318 25.9 37.9	Acruz					
03	163 25.3	242 45.3 .. 59.6	205 30.5 .. 21.5	333 22.6 .. 49.0	333 28.4 .. 37.9	Adhar					
04	178 27.8	257 44.4 59.6	220 31.0 20.9	348 25.0 49.0	348 30.8 37.9	Aldebe					
05	193 30.3	272 43.4 59.4	235 31.5 20.3	3 27.4 49.0	3 33.3 37.9						
06	208 32.7	287 42.5 S22 59.2	250 32.0 S17 19.7	18 29.8 S 2 49.1	18 35.8 S 1 37.9	Alieth					
07	223 35.2	302 41.6 59.1	265 32.5 19.2	33 32.2 49.1	33 38.2 37.8	Alkaid					
08	238 37.6	317 40.6 59.0	280 33.0 18.6	48 34.7 49.1	48 40.7 37.8	Al Na					
M 09	253 40.1	332 39.7 .. 58.8	295 33.4 .. 18.0	63 37.1 .. 49.1	63 43.2 .. 37.8	Alnila					
O 10	268 42.6	347 38.8 58.7	310 33.9 17.4	78 39.5 49.1	78 45.6 37.8	Alph					
N 11	283 45.0	2 37.8 58.6	325 34.4 16.8	93 41.9 49.1	93 48.1 37.8						
D 12	298 47.5	17 36.9 S22 58.5	340 34.9 S17 16.2	108 44.3 S 2 49.1	108 50.5 S 1 37.8	Alphe					
A 13	313 50.0	32 36.0 58.3	355 35.4 15.6	123 46.8 49.1	123 53.0 37.8	Alphe					
Y 14	328 52.4	47 35.0 58.2	10 35.9 15.0	138 49.2 49.1	138 55.5 37.8	Alrai					
15	343 54.9	62 34.1 .. 58.0	25 36.4 .. 14.4	153 51.6 .. 49.1	153 57.9 .. 37.7	Anta					
16	358 57.4	77 33.2 57.9	40 36.9 13.8	168 54.0 49.1	169 00.4 37.7	Anta					
17	13 59.8	92 32.2 57.8	55 37.4 13.2	183 56.4 49.1	184 02.9 37.7						
18	29 02.3	107 31.3 S22 57.6	70 37.9 S17 12.6	198 58.9 S 2 49.1	199 05.3 S 1 37.7	Arct					
19	44 04.8	122 30.4 57.5	85 38.4 12.1	214 01.3 49.1	214 07.8 37.7	Arct					
20	59 07.2	137 29.4 57.3	100 38.9 11.5	229 03.7 49.1	229 10.2 37.7	Arct					
21	74 09.7	152 28.5 .. 57.2	115 39.3 .. 10.9	244 06.1 .. 49.1	244 12.7 .. 37.7	Bell					
22	89 12.1	167 27.6 57.1	130 39.8 10.3	259 08.6 49.2	259 15.2 37.7	Bete					
23	104 14.6	182 26.6 56.9	145 40.3 09.7	274 11.0 49.2	274 17.6 37.6						
20 00	119 17.1	197 25.7 S22 56.8	160 40.8 S17 09.1	289 13.4 S 2 49.2	289 20.1 S 1 37.6	Can					
01	134 19.5	212 24.8 56.6	175 41.3 08.5	304 15.8 49.2	304 22.6 37.6	Cap					
02	149 22.0	227 23.8 56.5	190 41.8 07.9	319 18.3 49.2	319 25.0 37.6	Cap					
03	164 24.5	242 22.9 .. 56.3	205 42.3 .. 07.3	334 20.7 .. 49.2	334 27.5 .. 37.6	Der					
04	179 26.9	257 22.0 56.2	220 42.8 06.7	349 23.1 49.2	349 30.0 37.6	Dip					
05	194 29.4	272 21.1 56.0	235 43.3 06.1	4 25.5 49.2	4 32.4 37.6						
06	209 31.9	287 20.1 S22 55.9	250 43.8 S17 05.5	19 28.0 S 2 49.2	19 34.9 S 1 37.5	Dul					
07	224 34.3	302 19.2 55.7	265 44.3 04.9	34 30.4 49.2	34 37.4 37.5	Ele					
08	239 36.8	317 18.3 55.5	280 44.8 04.3	49 32.8 49.2	49 39.8 37.5	Ele					
T 09	254 39.2	332 17.3 .. 55.4	295 45.3 .. 03.7	64 35.2 .. 49.2	64 42.3 .. 37.5	Ele					
U 10	269 41.7	347 16.4 55.2	310 45.8 03.1	79 37.7 49.2	79 44.8 37.5	Ele					
S 11	284 44.2	2 15.5 55.1	325 46.3 02.5	94 40.1 49.2	94 47.2 37.5	Ele					
D 12	299 46.6	17 14.5 S22 54.9	340 46.8 S17 01.9	109 42.5 S 2 49.2	109 49.7 S 1 37.5	Ele					
A 13	314 49.1	32 13.6 54.7	355 47.3 01.3	124 45.0 49.2	124 52.2 37.5	Ele					
Y 14	329 51.6	47 12.7 54.6	10 47.8 00.7	139 47.4 49.2	139 54.6 37.5	Ele					
15	344 54.0	62 11.8 .. 54.4	25 48.3 17 00.1	154 49.8 .. 49.2	154 57.1 .. 37.5	Ele					
16	359 56.5	77 10.8 54.2	40 48.7 16 59.5	169 52.2 49.2	169 59.6 37.5	Ele					
17	14 59.0	92 09.9 54.1	55 49.2 58.9	184 54.7 49.2	185 37.5	Ele					
18	30 01.4	107 09.0 S22 53.9	70 49.7 S16 58.3	199 57.1 S 2 49.2	200 37.5	Ele					
19	45 03.9	122 08.0 53.7	85 50.2 57.7	214 59.5 49.2	215 37.5	Ele					
20	60 06.4	137 07.1 53.6	100 50.7 57.1	230 02.0 49.2	231 37.5	Ele					
21	75 08.8	152 06.2 .. 53.4	115 51.2 .. 56.5	245 04.4 .. 49.2	246 37.5	Ele					
22	90 11.3	167 05.3 53.2	130 51.7 55.9	260 06.8 49.2	261 37.5	Ele					
23	105 13.7	182 04.3 53.0	145 52.2 55.3	275 09.3 49.2	276 37.5	Ele					
21 00	120 16.2	197 03.4 S22 52.9	160 52.7 S17 01.1	290 11.7 S 2 49.2	290 18.9 S 1 37.5	Ele					
01	135 18.6	212 02.5 52.7	175 53.2 00.5	305 14.1 49.2	305 21.3 37.5	Ele					
02	150 21.0	227 01.6 52.5	190 53.7 00.0	320 16.5 49.2	320 23.7 37.5	Ele					

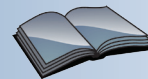

# Radar Workbook

## *Problems and Answers in Marine Radar Operations*

by David Burch and Larry Brandt

Question and answers on marine radar designed to accompany the Radar for Mariners. There are multiple choice questions and “points of ponder” questions for each of the seven lessons listed in our online course on radar along with the answers. Blank radar plotting sheets are included along with a list of common radar abbreviations. This workbook is in use by numerous schools throughout the US. Anyone who answers all the questions in this workbook has a sound understanding of the fundamentals of marine radar operation.

The Appendix on advanced radar plotting has been added for professional mariners who seek more practice on interpreting ARPA output by working out the vector solutions themselves. The ability to manually interpret the radar interactions seen on the screen independent of electronic solutions is in keeping with the fundamental tenet of good navigation and seamanship that we should not rely on any one aid alone.

For individual study or use in a classroom.

Turns your textbook into a home study course on radar.

- For all radar users, recreational and professional
- Radar operation
- Radar watch
- Chart navigation
- Blind pilotage
- Collision avoidance

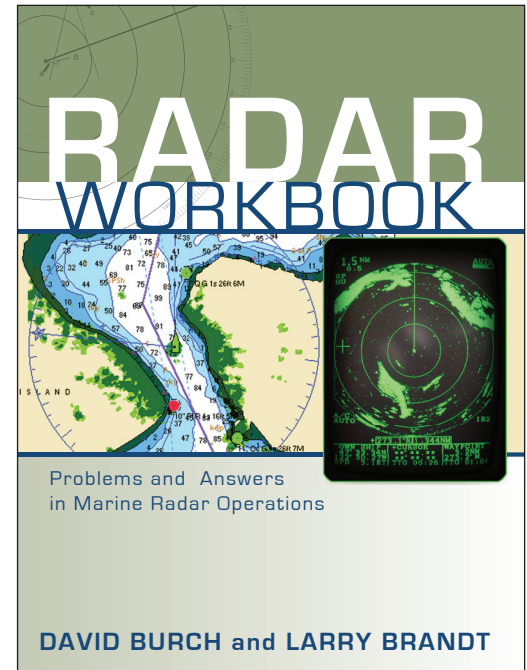

\$19.95, ISBN 978-0-914025-15-3  
104 pages, 8.25"x11"

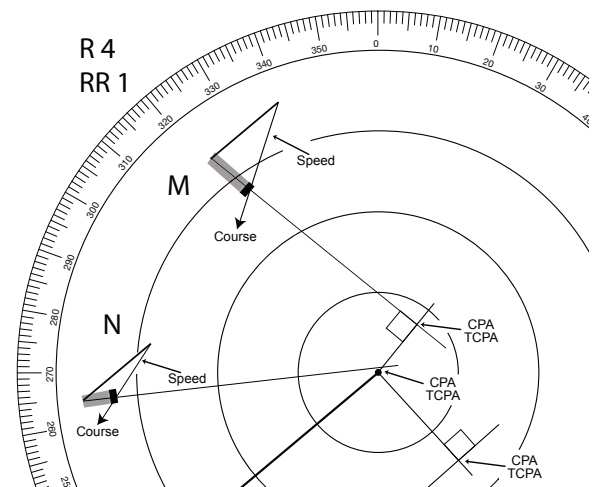

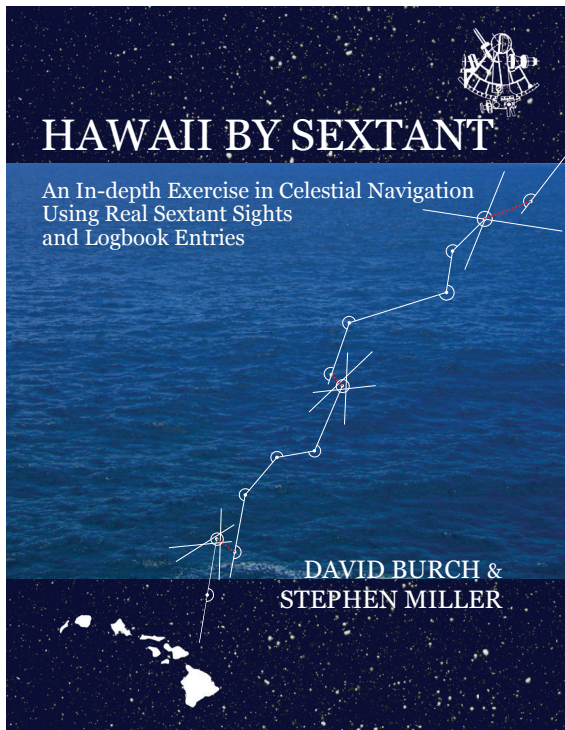

\$29.00, 978-0-914025-18-4  
8.5" x 11" paperback, 162 pages

## Ocean Navigation Practice Voyage

By David Burch and Stephen Miller

In the spirit of early Bowditch editions, we offer navigation details of a full ocean passage as an excellent way to learn the ropes of practical celestial navigation. With your own tables and plotting sheets, you can analyze 224 timed sextant sights to obtain 26 position fixes to find your way along a 2,800-nmi voyage lasting 17 days. We use sun, moon, stars, and planets.

After completing this passage you will be prepared to navigate by celestial navigation on your own – if you choose to, or need to.

The book includes an in-depth discussion with examples of the Fit-Slope Method, along with the formulation and examples of numerical LOP advancement for small DR corrections during a sight session and other suggestions for optimizing cel nav when combining traditional and modern solutions to position fixing.

Also included is a record of our rendezvous with the remnants of Hurricane Daniel, and other nuances, such as evidence of loose-cannon meso-scale current eddies—something that we (and most other navigators at the time) did not even know existed in these waters.

Solutions are provided by computation, filled-out workforms, and detailed plots using universal plotting sheets. After each fix, the range and bearing DR to Fix is recorded and discussed in light of proposed guidelines for ocean DR uncertainty.

Landfall at night using computed navigation light ranges is also discussed and illustrated.

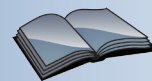

# Mariner's Pressure Atlas

By David Burch

The primary goal of this publication is to make mariners more aware of barometric pressure and how it might add to the safety and efficiency of their time on the water and to provide a specific, dependable method of storm warning in the tropics.

It is also intended to show the great value of an accurate barometer. The days of only caring about rise and fall, fast or slow, should be relegated to the history books. We now have ready access to accurate instruments and all the benefits they provide.

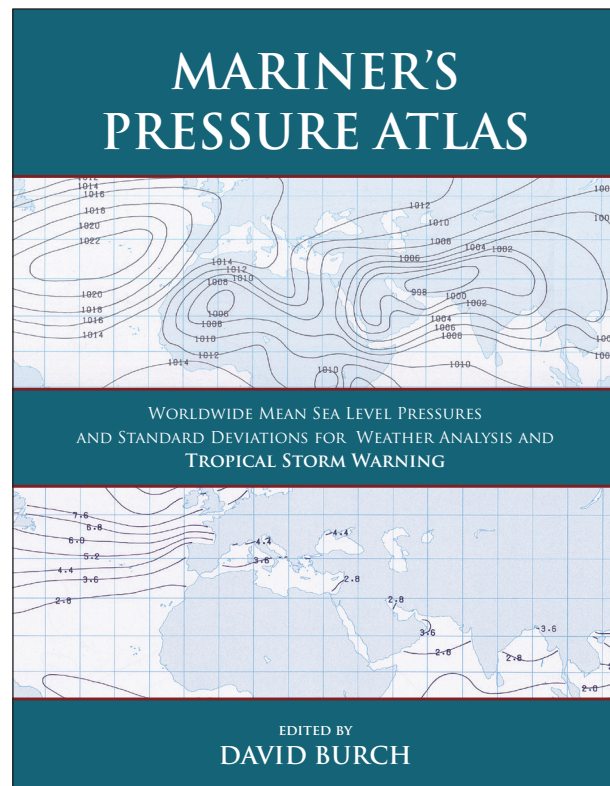

\$19.95, 978-0-914025-38-2  
8.5" x 11" paperback, 70 pages



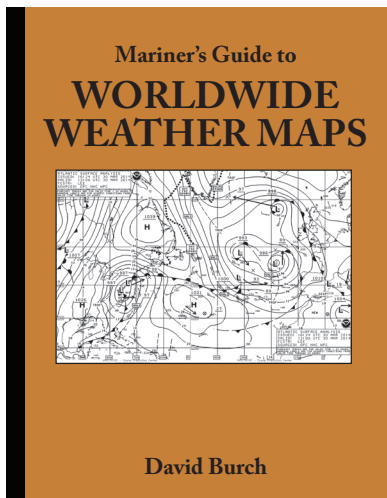

\$TBD, 978-0-914025-42-9

***Forthcoming...***

## **Mariner's Guide to Worldwide Weather Maps**

By David Burch

In this age of Internet and satellite phone communications we have access to a huge selection of weather maps for all parts of the world. This publication documents available maps by graphical index, along with details for obtaining them by wireless methods on land and underway along with a description of each. Map symbols and conventions are also included.

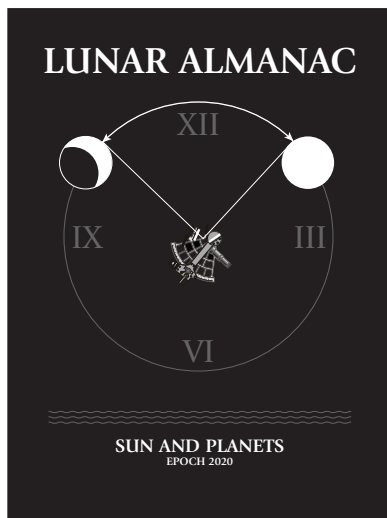

\$TBD, 978-0-914025-24-5

***Forthcoming...***

## **Lunar Almanac**

Starpath and Associates

The ultimate back up for ocean navigators. This book provides the lunar distance between the moon and sun and selected bodies, every 3 hours for 10 years. From this data and the measured lunar distance a navigator can find the correct Universal Time and from that their longitude. Correct time is the most valuable aid to ocean navigation, so with this book navigators can carry on with safe navigation even if they should lose all conventional sources of accurate time.

This lunar data along with the *Stark Tables for Clearing the Lunar Distance* and Kolbe's *Long Term Almanac* makes any navigator completely independent of all outside assistance for the next decade. Thus this book can be thought of as the *Doomsday Almanac*, or simply a convenient way to practice and master the valuable skill of finding longitude by lunar distances to achieve a high level of independence.

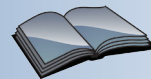



# SOFTWARE



**Click any item to purchase online**



\$159.00, Item 1801, CD ROM for Windows

## Radar Trainer

***Master radar on your computer screen***

This program was designed for those who are brand new to radar, but it is so realistic and so versatile that it is also used by navies, coast guards, merchant marine, and navigation schools around the world. The first version of this program was the first PC software ever approved by the USCG for use in certified radar endorsement schools.

Just a few hours practice with the Radar Trainer will make a world of difference to the anxiety level experienced when you first encounter a radar target bearing down on you in the fog. Practice with radar navigation using its realistic simulated land images to learn how to negotiate tricky entrances to harbors in the fog.

This is an all new version of a program that has been in use around the world since 1990. It teaches all aspects of radar use including radar navigation and piloting using realistic land simulations with thorough in-line tutorials along with all the features of ver 2 to master collision avoidance using built-in traffic patterns and chart scenarios in very convenient and versatile radar simulators.

“There are very few teaching aids as effective as hands-on experience. The newest Radar Trainer software from Starpath is as close as you’ll get to hands-on short of hopping aboard a boat and taking a working radar to sea... an unqualified thumbs-up that it does what creator David Burch claims it can do.”  
— Blue Water Sailing Magazine

““Accelerates the learning curve ...highly recommended” — Practical Sailor and Powerboat Reports

“Splendid and thorough... A masterful job of turning a rather abstruse subject into a straightforward one... It just might save your life or someone else’s one day!” — The Ensign, US Power Squadrons

***The world’s first PC radar simulator remains the most popular.***



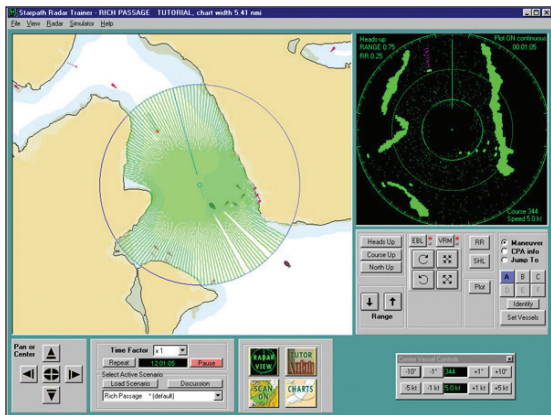

When you first start Radar Trainer 3 it is running in the Chart View on a default chart with default traffic. It will always start in exactly the same manner and mode. There are 3 vessels set, a "center vessel," whose radar you are observing, and 2 active targets. The targets show up as red dots on the chart leaving gray trails behind them. In the small radar screen, the plot option is turned on which leave purple trails on the radar screen. The simulator is running with a time factor of 3, which means the action is evolving 3 times faster than it normally would for the speeds assigned to yourself and the targets. You can vary the time factor from real time (factor 1) up to a factor of 10.

If you care to see on the chart the region you are viewing on the radar, press the Scan button which will show as a green sweep on the chart precisely what the radar sweep is interacting with. The controls on the bottom left are used to drive the center vessel, the pan and center buttons on the bottom right are used to move about the chart window. Traffic is set on the chart window by drag and drop from the Set Vessels window (not shown).

In Radar View the radar screen fills your computer screen. This is the view that must be used for the practice exercises in navigation and piloting. For each land region simulated, there are pdf versions of the charts that can be printed and used for reference as you navigate with the radar.

The full Radar Trainer 3 package contains many resources. The best bet is to skim through the introductory parts of the Help and Tutorial. This will acquaint you with the simulator and the various resources. There are organized Lesson Plans, as well as a set of Practice Exercises with answers. If you cared to, you could go straight to the exercises to work with them and from there learn what areas might need some review and then turn to those specific sections of the Tutorial.

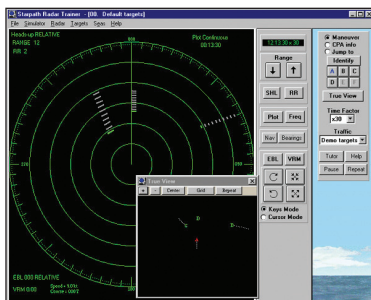
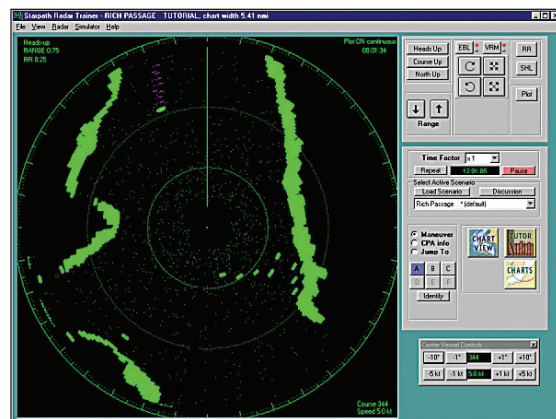

You have two complete programs in this package, the Radar Trainer 3, which we call RT3, and an upgraded interlinked version of our veteran Radar Trainer 2 which is now called RT2a. In a nutshell, the new RT3 is designed to teach radar interactions with land and basic interactions with traffic, whereas RT2a is better suited for more detailed study of collision avoidance and radar maneuvering in traffic. The two programs have a similar structure and it is easy to switch back and forth between them as desired.



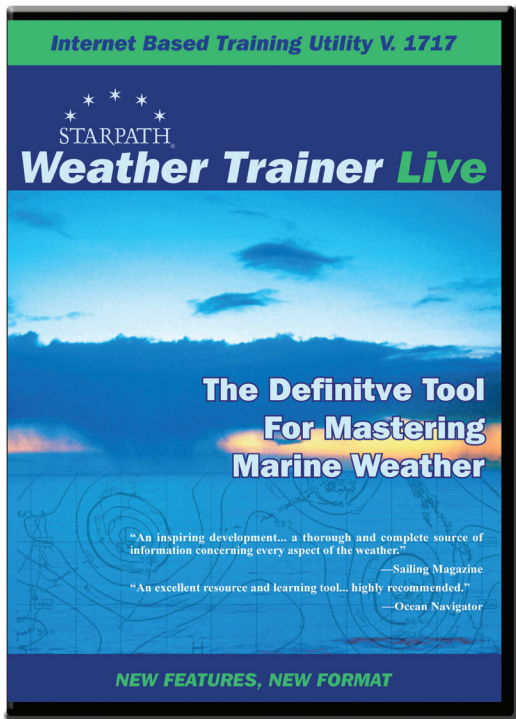

\$89.00, Item 1717, CD ROM for Windows  
Requires Internet connection

## Weather Trainer Live

***Your knowledge of weather affects your safety and comfort at sea. Take command with the Starpath Weather Trainer.***

Weather technology provides mariners with increasingly sophisticated resources. The new Starpath Weather Trainer Live teaches you how they work and where to find them. Subjects include: Obtaining and using GRIB formatted data; NAVTEX broadcasts; standard and new radio sources; weather by cell phone and sat phone; HF high seas reports; radiofacsimile weather maps; weather maps by email underway; ASCAT; use of Internet for planning, and more. This program will make you an expert at weather map reading and usage.

Traditional skills will always prove to be irreplaceable in prudent navigation. For traditionalists (and those who know Murphy's Law still applies to on-board electronics) Weather Trainer Live offers a dynamic, hands-on way to identify and analyze the eternal natural signs of wind, sea, and sky. You'll learn how to use your barometer to its full potential, recognize clouds and their meanings, interpret changes in wind and sea conditions, and how to mold these observations into a realistic picture of existing and impending weather. And you'll learn how to use these observations to evaluate and fine tune official reports and weather maps.

## All new "cloud" format

Weather Trainer Live includes an interactive annual training service that requires an Internet connection. All of the new live data and connections are stored on the Internet using what has come to be called the "cloud technology." This is a look into the future of software. Once you login to the program via the Internet you are assured to have the latest version of all teaching materials and working resources, and then you can use them live online or print them for future use off line. Your purchase of this product provides one year of full access to the Weather Trainer Live program along with a permanent ebook copy of the text *Modern Marine Weather*, *The Barometer Handbook*, and two other ebook training manuals on marine weather.

**"The Weather Trainer software is a powerful teaching tool that will help all mariners, professional and recreational, better understand how to apply the forecasts and weather maps to enhance the safety and enjoyment of their time on the water." — Lee Chesneau, Marine Predictions Center, U. S. National Weather Service**





The interactive graphic index supplements the menu bar. New components include GRIB map analysis compared to man-made weather maps

“...an excellent resource and learning tool... highly recommended.”  
— Ocean Navigator Magazine

“...an inspiring development... a thorough and complete source of information concerning every aspect of the weather. ...the benchmark weather resource.”  
— David Berson, Sailing Magazine

Now includes the best live worldwide marine weather links as well as detailed instructions on use of latest technologies, such as the European ASCAT scatterometer wind data.

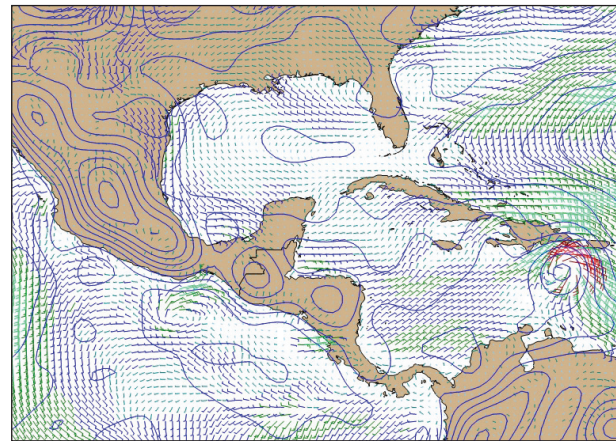
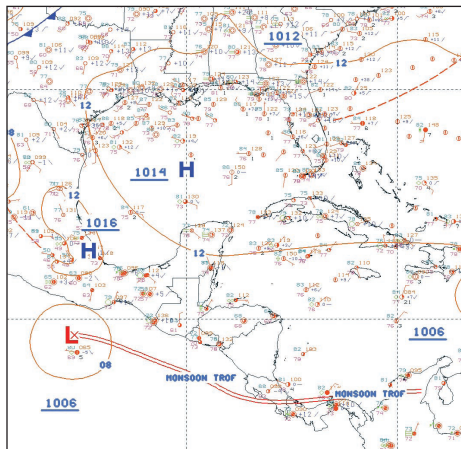

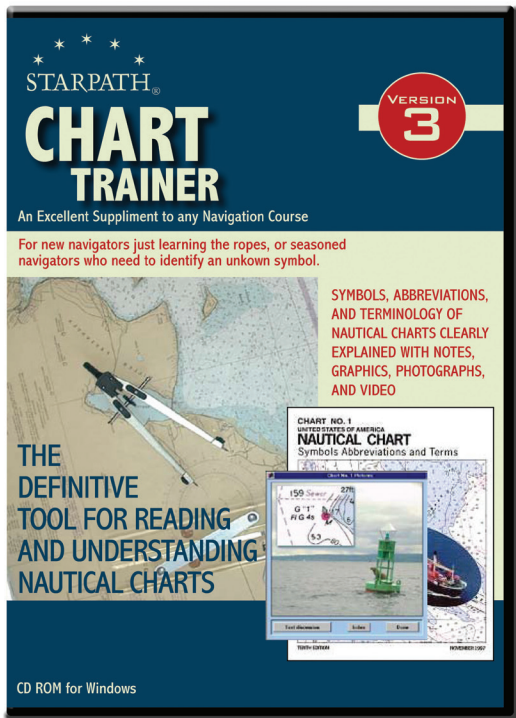

\$39.00, Item 1814, CD ROM for Windows

## Chart Trainer

*Learn to read nautical charts like an expert*

Chart Trainer is designed to help mariners interpret nautical charts and use them more efficiently, both traditional paper charts and new digital charts for computers. The materials cover all aspects of nautical charts in the most detail available, including tutorials on chart reading and plotting, along with the official definitions of all nautical chart symbols and plain-language explanations of chart features and conventions.

New navigators can master the use of charts starting from the basics. Experienced mariners can use this program to look up special or uncommon chart symbols or notations using the super-convenient layout and search capabilities. We also include a unique graphic search function.

We have added photographs of common nav aids and other charted features to help clarify their symbols. In many cases these photographs are annotated to point out important aspects of their chart presentations. Also included is an animated presentation of light characteristics to help navigators identify lights and to correlate the symbols with what they represent.

Some US charts of foreign waters include terms and abbreviations in the local languages. Consequently, in addition to our extensive list of English terms and abbreviations, we have included here a searchable list of these foreign language terms, organized by country of origin. We have also included an international list of hydrographic offices. These are the sources for charts and navigational publications of other nations.

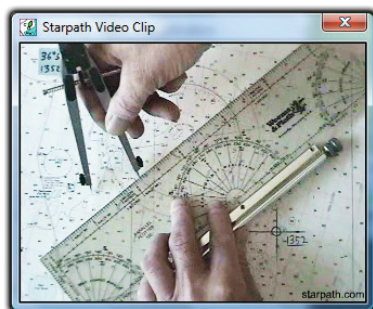

There are nine video and slide presentations of various aspects of chart plotting included in Chart Trainer. These are intended to help those new to chart work learn the basic use of plotting tools.

The text discussion includes a step-by-step outline of the procedure, followed by a section called "Video Notes" which goes into more detail about the actual plot being made and related matters. Audio has been added to these movies in this version 3.

***Now covers echarts and new online sources for echarts.***

***See [www.starpath.com/getcharts](http://www.starpath.com/getcharts)***



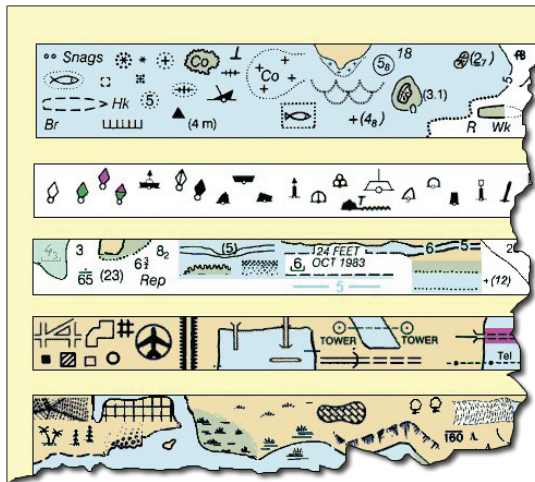

With the unique graphic index, you can just look for the symbol of interest, and then click it. That will take you to the appropriate section. In that section there will be links to photographs and text discussions. In lieu of mouse clicks, using the keyboard, type the letter beside the highlighted box to go there.

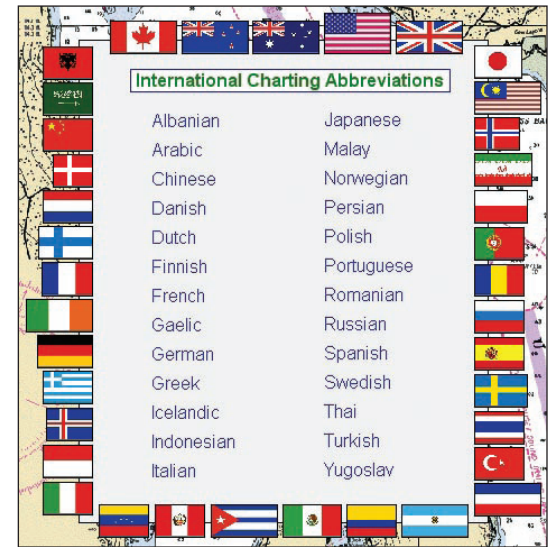

Indexes to charting abbreviations given in 26 languages

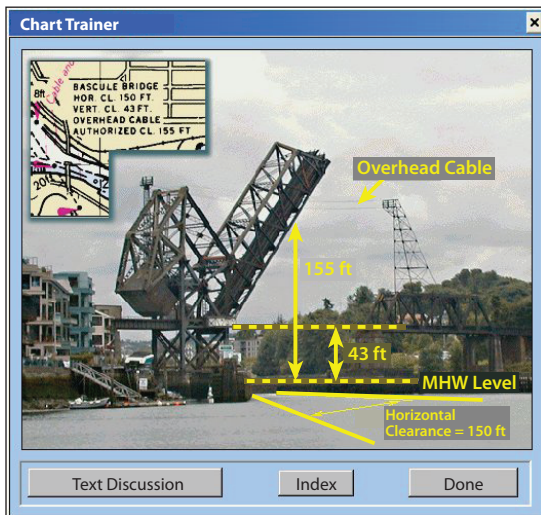

Annotated graphics show how you can interact with the photos and graphics of Chart Trainer to show details, like this one. Other options show other perspectives of the same object, or same object at high and low water, or various examples of the same thing.

To show an inset in any of the photos or chart samples, you just click the label or button describing it, and to hide it, you just click it again.

"I opened it last night and was very pleasantly surprised with the details on ATONs including images and simulations. The notes button has additional useful information. All in all Chart Trainer is well worth the price of admission! The only drawback was I stayed up way too late last night drilling into details on Lights and Lighthouses. It was a never ending source interesting info." — TD, Eugene, OR



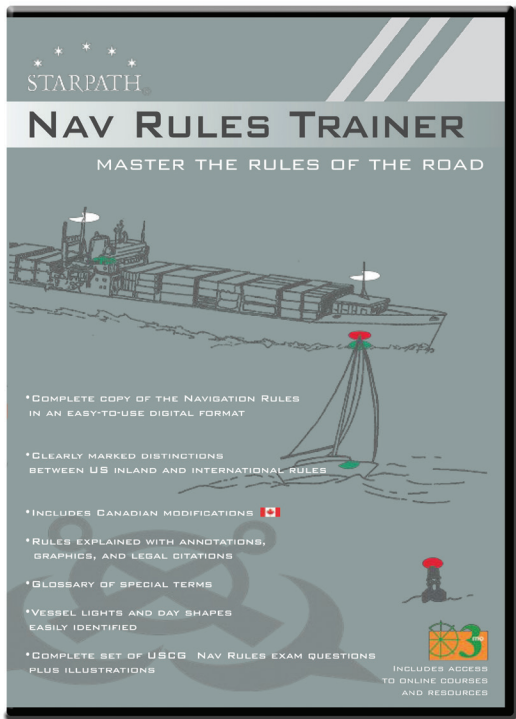

\$89.00, Item 1816. CD ROM for Windows

"Today I was successful in passing the new 3rd Mate exams! I owe a large part of this to my use of your excellent programs, especially the Chart Trainer and the NavRules Trainer. These products made my studies very interesting and I was able to breeze thru a tremendous amount of information very rapidly. THANK YOU for your efforts on behalf of the maritime industry. Best regards." — MT, 3rd Mate, Any Oceans

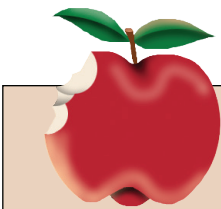

The entire data base of all USCG Exam questions on the Navigation Rules are presented for practice using the Starpath Examiner Module (see Captains Examiner). These questions are no longer available from the USCG.

## Nav Rules Trainer

*The beginner's best bet, and the professional navigator's first choice for reviewing the Rules of the Nautical Road.*

A training tool and resource for anyone who wants to learn the Rules of the Road thoroughly—for their own safety or for preparation for a USCG license exam. It includes detailed explanations of each Rule and a powerful self testing module (Starpath Examiner) used to study an enormous data base of questions on the Rules, along with unique vessel lights presentations and a detailed treatment of the Nav Rules that pertain to radar.

It includes complete, fully illustrated, indexed and searchable, electronic versions of the Navigation Rules for International Waters, US Inland Waters, and Canadian Waters, plus

- High resolution pdf copies of the US and International Rules that can be printed for a personal hard copy edition
- Explanations and court citations for each Rule
- Selected USCG exam questions, fully explained, that best illustrate each Rule
- Plain language Glossary that explains each key term used in the Rules
- Special section that explains the role of radar in the Navigation Rules
- Diagrams of all vessel lights organized by color pattern as well as vessel type.
- Detailed section showing every single difference between the US Inland and the International Rules, color coded to mark the significance of each difference.
- Special Annotated Table of Contents to help locate which Rule covers which topic.
- New section on how to use this product to study for USCG license exams.





Includes a high resolution pdf version of the Navigation Rules, US Inland and International, which is an identical copy of the USCG publication. It can be printed for a sharp copy of the Rules, which is required to have onboard all vessels over 12 meters on Inland Waters.

Unlike the original, however, this one is fully searchable by word or phrase using our custom index we have built for it. Look up, for example, all references to "barge lights," or "sailing vessels," or find the single reference to the word "ice" in the Rules — it is the only specific reference in the Rules to avoiding collisions with objects other than vessels.

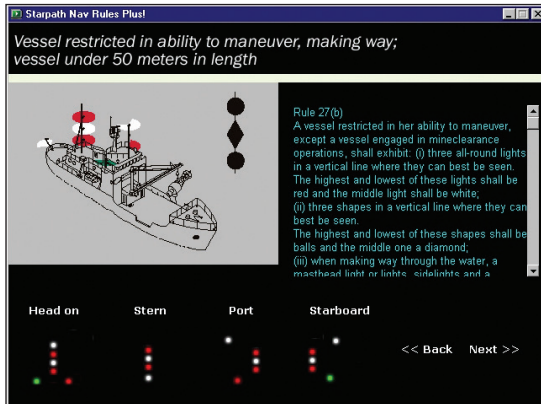
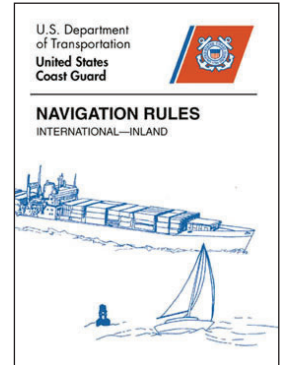

Navigation lights are presented in two formats, one organized by vessel type and the other organized by color pattern. The latter is a vast collection of every possible combination of lights by color (ie red only; red and white only; red, white and green only, etc). Each is then identified by simply rolling the cursor over the light pattern.

There is also a separate section that lists all the lights that appear in the USCG Nav Rules exam diagram books. Also included are special sections that list US Navy vessel light options, as well as the modifications of the Nav Rules used in Canadian waters.

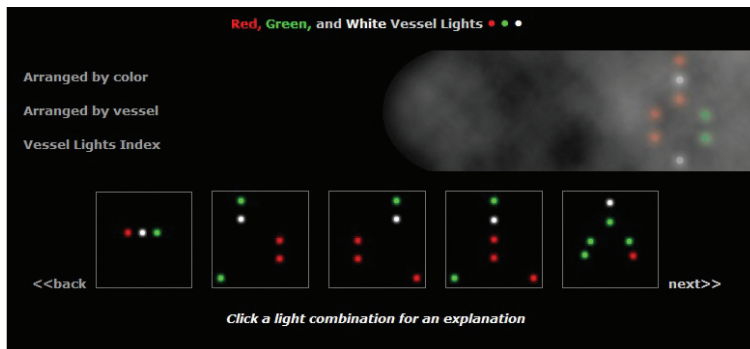

When navigating in the fog, the Navigation Rules that pertain to radar usage become paramount. Nav Rules Trainer includes a tutorial module called "Starpath Radar Rules" which explains in detail all references to radar in the Navigation Rules — six rules refer directly or indirectly to radar — including an in-depth, animated explanation of the often misunderstood Rule 19d. The Tutorial demonstrates numerous scenarios in which Rule 19d comes into play, and shows what happens when only vessel A or B maneuver correctly as well as both vessels maneuvering correctly, from the point of view of each vessel's radar screen. It also includes the true motion seen from above for each scenario.

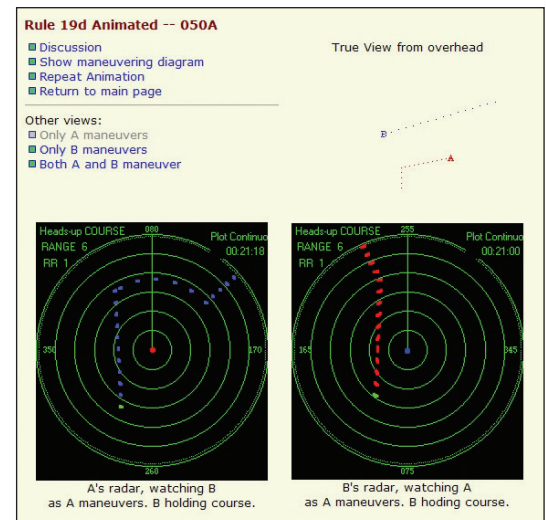

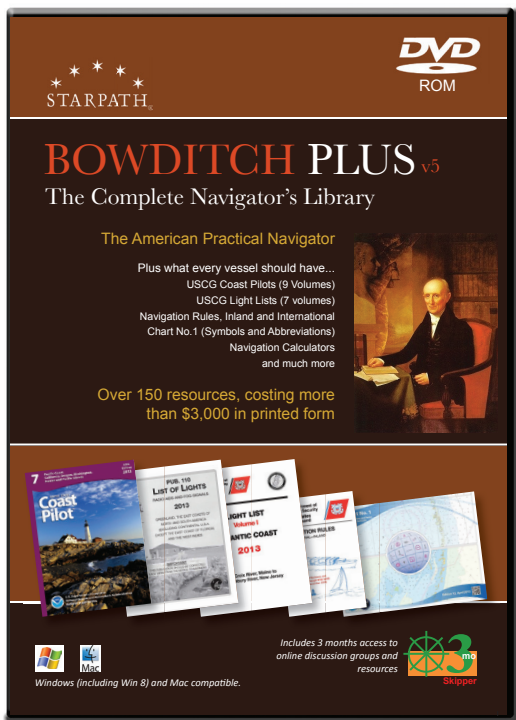

\$59.00, Item 1807, DVD ROM for Windows

“There are more than 114 volumes in total in Bowditch Plus!. There’s such a wealth of information that it will certainly be a much-referenced source aboard any cruising boat. And the price is a good deal, too, with the print version of Bowditch alone costing more than \$50.”

— Cruising World Magazine

## Bowditch Plus!

### The Complete Navigator's Library on one DVD

Includes The American Practical Navigator, Pub. No. 9, now called “Bowditch”. Complete text and illustrations of this classic 800-page reference book on marine navigation, fully searchable and indexed, presented in convenient Adobe Acrobat Reader format (pdf). Plus these additional full texts:

- World Sailing Directions
- Pilot Charts
- USCG Light Lists
- Navigation Table Data and Calculators
- Chart Symbols and Abbreviations
- Navigation Rules
- World Port Index
- Nautical Chart User’s Manual
- Distances Between Ports (Pub 151)
- Distances Between US Ports
- International Code of Signals (Pub 102)
- Radio Navigation Aids (Pub 117)
- Radar Navigation Manual (Pub 1310)
- Worldwide Marine Radiofacsimile Broadcast Schedules
- Mariner’s Guide to Hurricane Awareness
- Navigation Calculators (computes the old Vol. 2 Tables)
- Electronic Coast Pilots
- NIMA List of Lights
- Sight Reduction Tables
- Frequency List
- NWS Handbook
- MSC Charts

In short, the Bowditch Plus! package offers you some \$3000 worth of books, all fully searchable, plus the convenience of 39 numerical calculators for navigation computations.



# Engineer's Library

## Reference books for marine engineers.

This single CD includes elibra ebook editions of 50 volumes of books and self-study courses on all aspects of marine engineering. Each book is searchable for word or phrase with our unique Search/Find-all presentation of the context of each find.

Book Title	Pages
Interactive Index	1
Machinery Repairman 3 & 2	329
Diesel Engines	282
Engineman 3 & 2	568
Engineman 1 & C	312
Mathematics Fundamentals	304
Mathematics, Trigonometry	259
Refrigeration and Air Conditioning	108
Principles of Naval Engineering	664
Fire Room Operations	103
Basic Electricity	505
Tools and Their Uses	185
Marine Engineman's Handbook	440
Introduction to Marine Electricity	367
Gas Turbine Systems Supervisor	119
Fluid Power	236
Equipment Operator, Basic	633
Equipment Operator, Advanced	280
Basic Machines	169
Fireman	334
Machinist's Mate 3 & 2	542
Blueprint Reading and Sketching	198
Damage Controlman	385
Hull Maintenance Technician	717
Engineman 2	218
Electrician's Mate	624
Introduction to Matter, Energy, and Direct Current	270
Introduction to Alternating Current and Transformers	235

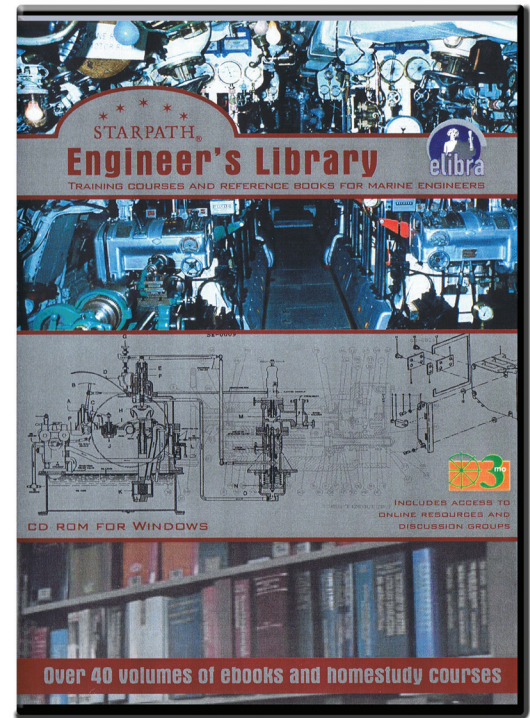

\$69.00, Item 1724, CD ROM for Windows

Introduction to Circuit Protection, Control, and Measurement	203
Introduction to Electrical Conductors, Wiring Techniques, and Schematic Reading / Radar Principles / Introduction to Test Equipment	145 / 188 / 256
Introduction to Generators and Motors / Modulation	112 / 216
Introduction to Electronic Emission, Tubes, and Power Supplies	193
Introduction to Solid-State Devices and Power Supplies	270
Introduction to Amplifiers / Microwave Principles	171 / 190
Introduction to Wave Generation and Wave Shaping	261
Introduction to Wave Propagation, Transmission Lines, and Antennas	261
Introduction to Number Systems and Logic Circuits	204
Introduction to Microelectronics / The Technician's Handbook	159 / 152
Principles of Synchros, Servos, and Gyros /	181
Radio-Frequency Communications Principles / Master Glossary	196 / 91
Test Methods and Practices / Introduction to Digital Computers	212 / 165
Magnetic Recording / Introduction to Fiber Optics	154 / 233



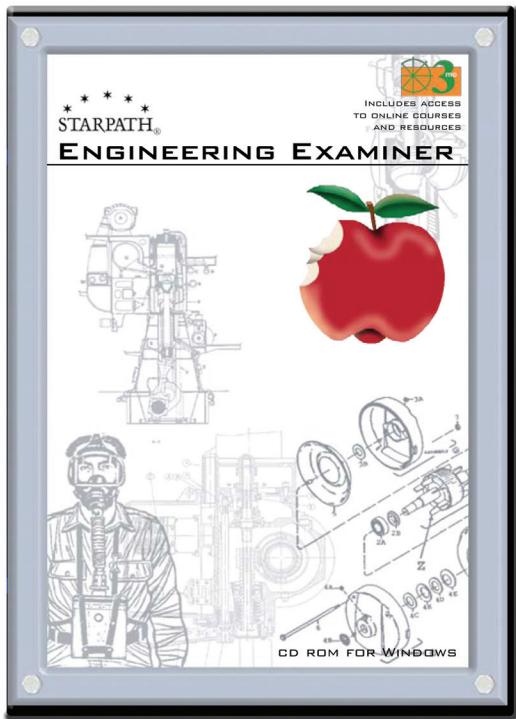

\$89.00, Item 1813, CD ROM for Windows

## Engineering Examiner

### *A unique resource for studying for an Engineering license*

This CD is a compilation of all the examination questions and diagrams used on USCG engineering exams. It includes the complete contents of these seven books, published by the USCG:

- Engineering General Subjects
- Electricity
- Engineering Safety
- Motor Plant
- Steam Plant
- Illustrations and Diagrams
- New and Revised Questions

The complete set of paper books sells for about \$270 (and obviously cannot be searched or filtered).

The questions are presented within the Starpath Examiner module, which allows users to select and filter the question database to meet their study needs. From any general topic, you can select out questions that match keywords of your choice. This filtered out pool of questions can then be filtered a second time for even more specific organization.

Then select the number of questions per test and the type of scoring (percent of test or percent of answers). All results can be saved, so on subsequent practice tests you can limit the questions to ones missed on the first test.

If a question contains a diagram, that diagram will appear automatically in a separate window at the click of a button, and the diagram can be zoomed or resized for convenient display. Many of the diagrams are very complex, and with this option you can study the illustrations in whatever detail is needed.

There is also an option for sorting (tagging) any question into two categories for subsequent study. One application of the tag scheme is to mark the “easy” ones that you do not want to ever see again, and the “hard” ones that you will want to come back to at some point.

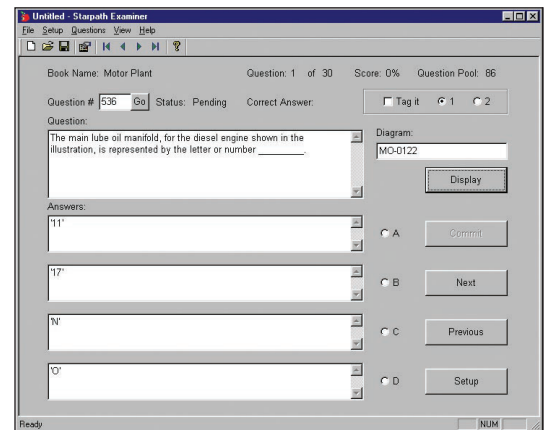

Questions window, showing 1st question of a test of 30, which have been filtered to include “lube oil,” as shown in the Set up window below it. When you save a session, the window will show that name, rather than “untitled.” There were 85 questions in the Motor Plant book that contained “lube oil” in the question.



# Captain's Examiner

*Hone your skills and keep them sharp with this extensive set of practice questions.*

This product presents some 9,000 USCG questions used in USCG deck license exams, along with all of the related graphics. The graphics can be zoomed and panned to study details. The questions are presented in several categories: Navigation Rules, Deck General, Navigation Problems, General Navigation, and Safety.

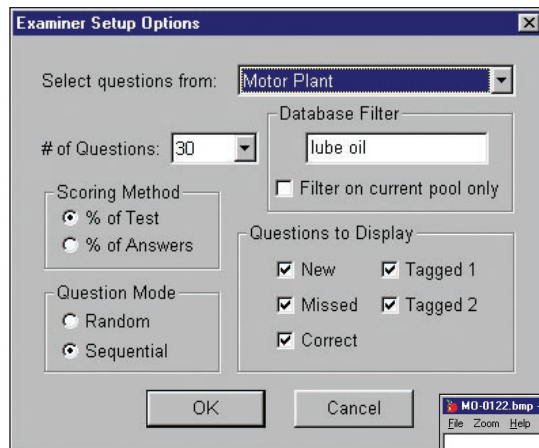

In the setup window you select the book, score method, presentation order, and filters.

The first view of the diagrams is of the entire picture. You can then zoom and resize to best see the parts you care about.

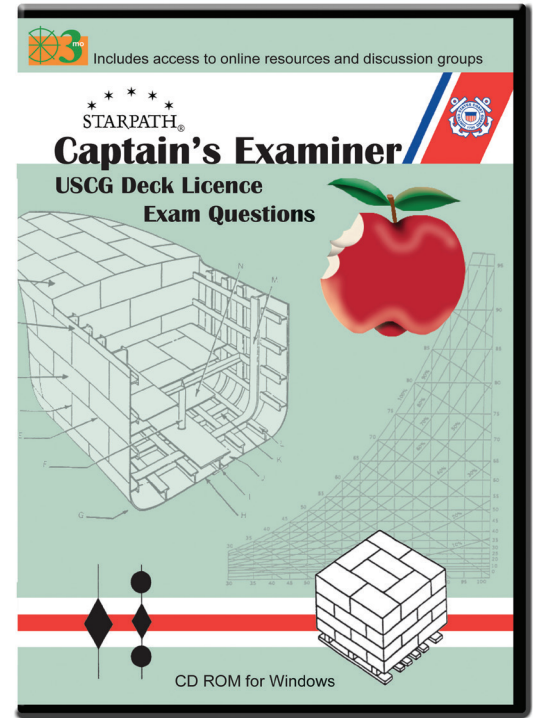
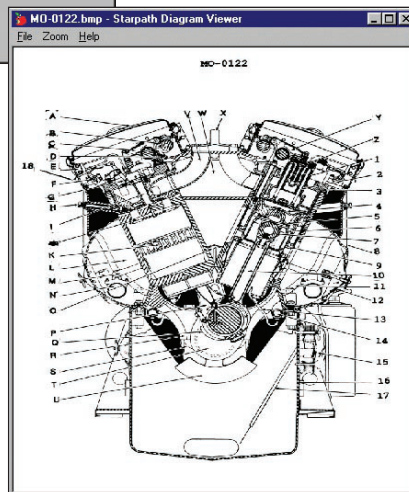

\$49.00, Item 1709, CD ROM for Windows

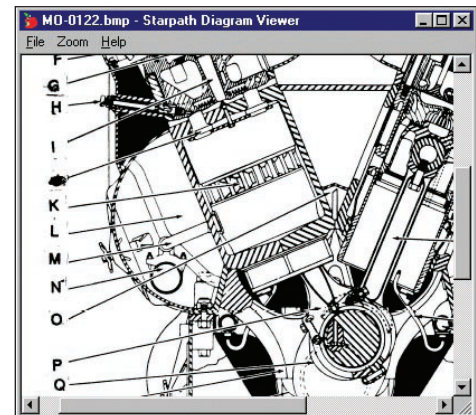

A zoomed view of the diagram.



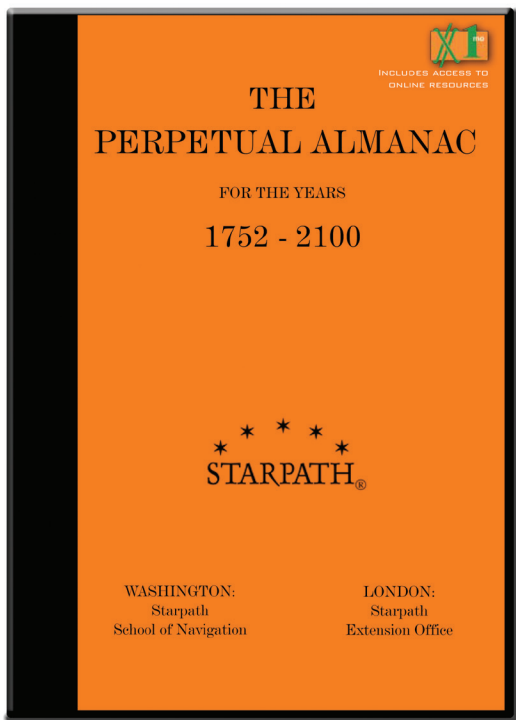

## The Perpetual Almanac

### *Reproduces Nautical Almanac Data until 2100*

Needless to say, we recommend a printed copy of the *Nautical Almanac* if you are relying upon celestial navigation underway, but if you have a computer onboard this simple program will provide a wonderful backup to a lost or out of date book. It might also be of interest to those who do only periodic cel nav on land. Printed versions cost some \$30 to \$50 *per year* depending on source, so this perpetual data could be an economical alternative.

It is extremely simple to use and provides all ephemeris data available in the paper editions, namely: GHA, Dec, SHA, SD, HP, magnitudes, sunrise, sunset, LAN, twilight times, moonrise, moonset, moon age and phase. We include sun, moon, 5 planets, and 270 stars, ie one more planet (Mercury) and many more stars than are in the nautical print version. In addition, we include Hc at LAN, bearing of sunrise and sunset (amplitudes), and the GHA of Aries midway between civil and nautical twilights for star planning.

Just enter a time and date from the convenient calendar selector, select your body, and get the data. You can get individual data, or ask for a print out of sequential data for the time interval and number of points you wish. The results have the same accuracy and precision as quoted in the print version of the *Nautical Almanac*.

\$49.00, Item 1811, CD ROM for Windows

***Ideal for historians as the data are accurate back to 1590. We have checked numerous historic sights including many from Lewis and Clark, etc.***

***Output data can be printed as tables***

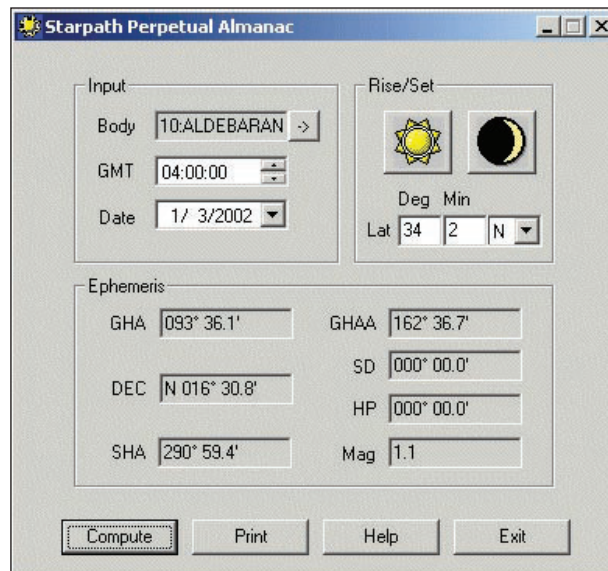

# *Fischer*<sup>®</sup> COLLECTION



**Click any item to purchase online**



**\$949.00, Item 103PMB**

Accuracy:  $\pm 0.7$  mb ( $\pm 0.02$  inHg)

Graduation: 0.5 mb and 0.01 inHg

Dial: flat white finish; diameter 5.1"

Units on dial: mb and inches of mercury

Housing Diameter: 6.5"

Weight: 1.6 pounds

Measuring Range: 890 to 1050 mb = 26.30" to 31.00"

For use at elevations below 2,600 ft.

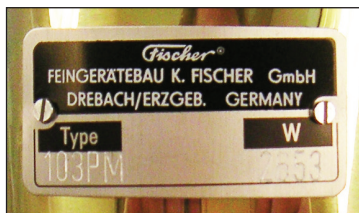

A certificate of accuracy is provided with each instrument. Each has a unique serial number on a metal plate on the top of the instrument.

## Precision Aneroid Barometer

### *Time-tested accuracy and durability*

Precision aneroid barometers are used for measuring the absolute atmospheric pressure. Because of the excellent instrument properties an aneroid barometer is indispensable for meteorology, ocean navigation, industry, and research.

The self-stabilized set of five aneroid capsules used in our precision aneroid barometers is made of a corrosion proof copper-beryllium-alloy. This alloy has been well established for measuring the atmospheric pressure for many years because of its remarkable elastic properties. These unique aneroid capsules are free of age-hardening, hysteresis and elastic after-effects.

The influence of temperature on the capsules and transmission system is compensated for over the whole measuring range and for temperatures between  $-30$  to  $+40$  °C ( $-22$  to  $104$  °F). The motion of the aneroid capsule is transmitted to the axle of the pointer by driving a segment and wheel with an excellent fine finish gearing. All bearings also have an excellent fine finish. The Instruments have only a bare minimum of idle friction because of the advantageous shape of the levers and bearings.

This is one of the highest quality aneroid barometers in the world. It has been tested at sea for over 70 years, and used by Navies and Weather Services around the world. The double needle design removes parallax error in reading. New dials showing both millibars (mb) and inches of mercury have been custom made for American and British users on land and sea.

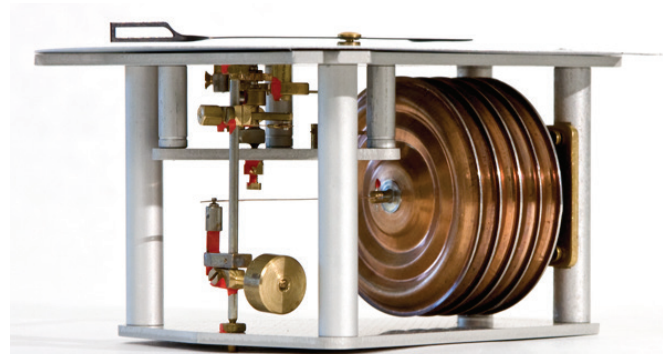



## Ship's Clock

***Silent and accurate***

The Ship's Clock model 103PMU has a silent, high-precision quartz movement made in Germany. They are designed to withstand the vibration, temperature and humidity extremes expected on vessels at sea. It can operate accurately for up to 2 years on a single "AA" battery. The Fischer Ship's Clock is suitable for the enclosed bridge, pilothouse, or nav station of any vessel. Vibration-isolation bushings are included for bulkhead mounts.

**\$175.00, Item 103PMU.** Features a large 4" diameter white dial, both 12-hour and 24-hour dials, sweep second hand that steps in 1-sec intervals, mounted in a brass cases (6" diameter x 3" tall)



## Precision Thermometer

**Matches the Precision Aneroid Barometer**

A precision analog temperature sensor made in Germany, intended for indoor use. The displayed temperature is accurate to  $\pm 1^{\circ}\text{C}$  ( $1.8^{\circ}\text{F}$ ) over its full range of  $-10^{\circ}\text{C}$  to  $+50^{\circ}\text{C}$  ( $14^{\circ}\text{F}$  to  $122^{\circ}\text{F}$ ).

The instrument is mounted in a well-ventilated protective brass housing (6" diameter x 3" tall). No battery or external power is required. The Fischer Ship's Thermometer is suitable for the enclosed bridge, pilothouse, or nav station of any vessel. Vibration-isolation bushings are included for bulkhead mounts.

**\$165.00, Item 103PMT.** Features a large 4" diameter white dial, with both Celsius and Fahrenheit scales. Model 103PMT-C has Celsius on the outside dial; model 103PMT-F has the Fahrenheit on the outside of the dial.



**\$179.00, Item 103 PMH**

Solid brass, base diameter 6.4 inches  
measuring range: 0 to 100% relative humidity  
accuracy:  $\pm 3\%$  relative humidity  
scale graduation: 1% relative humidity  
Operating range 0° to 70° C (32° to 158° F)



## Precision Hair Hygrometer

### *Award-winning accuracy and dependability*

The Fischer Synthetic Hair Hygrometer model 103PMH is a precision all-mechanical instrument that offers accurate relative humidity measurements. It is intended for indoor use, above freezing level.

Each instrument has a unique Serial Number and is tested at 3 points at the factory before shipment. They are then again confirmed with an NIST traceable Vaisala PTB300 at Starpath before shipping to customers.

Fischer Instruments holds the same world leader position in hygrometers as they do in barometers. They have won high awards for the hygrometers in European consumer reports and testing labs.

Relative humidity is a crucial factor in weather analysis and forecasting as well as human comfort. The data are also crucial to the safe storage of many products.

This instrument has been a prized product of the Fischer Company for more than 60 years. It has no electronic components. The sensor element is a specially treated synthetic fiber whose length is sensitive to the humidity in the air. For a given tension on the fiber bundle, the length increases with increasing relative humidity. Changes in its length are then magnified with precision gears to display the relative humidity of the air.

In contrast to real hair hygrometers, which must be chemically cleaned and rejuvenated often, this synthetic-fiber model provides high precision and fast response time with very little maintenance.

Relative humidity and accurate air temperature can be used to determine the dew point of the atmosphere using tables or portable applications. When the air temperature drops to the dew point fog will form.

Vibration-isolation bushings are included for bulkhead mounts.

STARPATH CORPORATION

3050 NW 63rd St.

Seattle, WA 98107

USA

*Excellence in nautical science since 1980.*

